

# Pneumatikzylinder *Pneumatic Cylinders*

**VDMA 24562**

**ISO 6431**



## INHALT / CONTENTS

<b>Pneumatikzylinder</b> <i>Pneumatic cylinders</i> .....	Seite / Page 2 - 10
<b>Theoretische Zylinderkräfte / Sonderversionen</b> <i>Theoretical cylinder thrust / special models</i> .....	Seite / Page 11 - 13
<b>Befestigung Kolbenstange</b> <i>Piston rod mounting</i> .....	Seite / Page 14 - 15
<b>Einbauvarianten</b> <i>Mounting options</i> .....	Seite / Page 16 - 20
<b>Magnet-Sensoren</b> <i>Magnetic sensors</i> .....	Seite / Page 20 - 21
<b>ISO Zylinder mit Feststelleinheit</b> <i>ISO cylinders with piston lock</i> .....	Seite / Page 22 - 24
<b>Legende</b> <i>Key</i> .....	Seite / Page 25
<b>Wichtige Hinweise / Gewährleistung</b> <i>Cautions / Warranty</i> .....	Seite / Page 26 - 27



<b>N</b>	<b>NBR 70 (Buna N) - Standard</b>
<b>H</b>	<b>Pur Polyurethane 92° ShA - Optional</b>
<b>V</b>	<b>VITON® - Optional</b>
<b>N</b>	<b>NBR 70 (Buna N) - Standard</b>
<b>V</b>	<b>VITON® - Optional</b>
	<b>Eloxiertes Aluminium</b> <i>Hard anodised Aluminium</i>
	<b>Stahl verzinkt</b> <i>Zinc plated steel</i>
	<b>Messing</b> <i>Brass</i>
<b>O • P • T</b>	<b>Stahl C40 mit Chromauftrag</b> <i>Steel C40 with chrome coating</i>
<b>C • R • A</b>	<b>INOX AISI 303 - mit Chromauftrag</b> <i>with chrome coating</i>
<b>X • W • Z</b>	<b>INOX AISI 303</b>
	<b>Wartungsfreie Lagerbuchse</b> <i>Self-lubricated bushing</i>
	<b>Führungsring aus PTFE + Carbographit</b> <i>PTFE + Carbographite ring</i>
	<b>Dämpfungsscheiben</b> <i>Shock pads</i>
	<b>Aluminium</b>

# Pneumatikzylinder • *Pneumatic cylinders*

Diese Pneumatikzylinder gemäß ISO-VDMA Norm werden vollständig an CNC - Werkzeugmaschinen mit numerischer Kontrolle hergestellt. Dadurch können verminderte Abmessungstoleranzen der Einzelbausteine und eine Leistungskonstanz dauerhaft garantiert werden. Die Zylinder und Enddeckel sind komplett eloxiert, um eine geringere Abnutzung und einen größeren Korrosionswiderstand zu erreichen. Die Fähigkeit, eine bestimmte Menge an Flexionalbelastungen zu bewältigen, wird durch die Führungsringe im Zylinderkopf sowie den PTFE-Kolbenführungsring erreicht. Darüber hinaus zeichnen sich unsere Zylinder durch pneumatische Endlagendämpfung mit mikrometrischer Einstellung und die serienmäßige Ausstattung mit elastischen Dämpfungsscheiben aus. Die Zylinder sind in vier Varianten mit jeweils unterschiedlichen Dichtungsmaterialien und Eigenschaften zur Bewältigung von Flexionalbelastungen erhältlich. Zwei Bauarten sind verfügbar: mit Zugstangen aus Stahl (Material: INOX) oder Aluminiumprofil. Alle Zylinder sind auch mit Magnetkolben für berührungslose Abfrage lieferbar (Hall- bzw. Reed-sensoren).

*ISO-VDMA pneumatic cylinders are manufactured on CNC machining centres to guarantee low dimensional tolerances and unvarying performance over a long period of time. The barrels and end-caps are fully anodized to reduce wear and increase corrosion resistance. End-caps guide bushings and PTFE piston guide rings ensure high resistance to side loads. Pneumatic micrometer-adjustable cushions and elastomer shock-pads also contribute to long, problem-free service. Four models (with varying seal materials and resistance to side loads) are available in two constructions {steel (material: INOX) tie rod or aluminium profile}. All models can be fitted on request with magnetic pistons for Hall or Reed effect position sensor.*

## “STANDARD”

- Standard mit Dichtungen NBR 70 (Buna N)
- Standard with NBR 70 (Buna N) seals

## “HEAVY”

- Geeignet für schwere Belastungen mit Dichtungen aus Pur Polyurethane 92° ShA
- For heavy duty applications with Pur Polyurethane 92° ShA seals

## “VIGOR”

- Geeignet für schwere Belastungen in schwieriger Umgebung mit Dichtungen aus VITON®
- For heavy duty applications in difficult environments, with VITON® seals

## “ACTION”

- Mit niedrigem Reibungskoeffizienten
- For low friction applications

### TECHNISCHE EIGENSCHAFTEN:

- Betriebsdruck
- Temperaturbereich
- Für ölfreien Betrieb geeignet

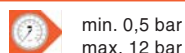

min. 0,5 bar  
max. 12 bar



min. -10°C  
max. +85°C



### TECHNICAL SPECIFICATIONS:

- Working pressure
- Ambient temperature range
- Suitable for oil-free operation

# Bestelldaten • Ordering data

## Bestellschlüssel für ROSS-Zylinder

D01	12	F	M	4	0	0500	H	0	P	C
<b>Modell:</b> <b>D01</b> Doppeltwirkende Pneumatikzylinder  <b>B01</b> Doppeltwirkende Pneumatikzylinder mit Feststellereinheit nur bis ø125 mm	<b>Kolben ø</b> <b>03</b> = 32 <b>04</b> = 40 <b>05</b> = 50 <b>06</b> = 63 <b>08</b> = 80 <b>10</b> = 100 <b>12</b> = 125 <b>16</b> = 160 <b>20</b> = 200 <b>25</b> = 250 <b>32</b> = 320	<b>Produktlinie</b>	<b>M</b> =mit Magnet <b>A</b> =ohne Magnet	<b>Anschlußgewinde:</b> <b>1</b> = 1/8" <b>2</b> = 1/4" <b>3</b> = 3/8" <b>4</b> = 1/2" <b>5</b> = 3/4" <b>6</b> = 1"	<b>Kolbenstange:</b> <b>0</b> =C40 verchromt <b>C</b> =Inox AISI 303 verchromt <b>X</b> =Inox AISI 303 verchromt <b>P</b> =C40 verchromt mit durchgehender Kolbenstange <b>R</b> =Inox AISI 303 verchromt mit durchgehender Kolbenstange <b>W</b> =Inox AISI 303 durchgehende Kolbenstange <b>T</b> =C40 verchromt, Tandem (ø 32-100) <b>A</b> =Inox AISI 303 verchromt, Tandem <b>Z</b> =Inox AISI 303, Tandem	<b>Hub in mm</b>	<b>Dichtungen:</b> <b>N</b> =Standard NBR 70 <b>H</b> =PUR 92° <b>V</b> =Viton (150°) <b>A</b> =reibungssarm	<b>Konstruktion:</b> <b>0</b> =Aluminium Profilrohr <b>Z</b> =Aluminium Profilrohr mit 4 Zugankern; ø 250 und 320 mm nur mit Zuganker <b>S</b> = Sonder, z.B. Faltenbalg	<b>Befestigung Stangenseite:</b> <b>0</b> =ohne <b>F</b> =Gabelkopf mit Clips <b>P</b> =Gabelkopf mit Bolzen <b>T</b> =Gelenkkopf, sphärisch <b>A</b> =Ausgleichskupplung	<b>Befestigung Bodenseite:</b> <b>0</b> =ohne <b>C</b> =Schwenkflansch mit Bolzen <b>D</b> =Schwenkflansch, "weiblich" <b>M</b> =Schwenkflansch, "männlich" <b>H</b> =Schwenkflansch sphärisches Auge <b>V</b> =Schwenkflansch mit Gegenlager <b>Z</b> =Lagerbock <b>A</b> =Frontflansch <b>B</b> =Fußwinkel <b>G</b> =Flansch bodenseitig <b>I</b> =Schwenklager, mittig fixiert <b>R</b> =Schwenklager, beweglich <b>L</b> =Lagerbock für Schwenklager I+R

## Order Code for ROSS-Cylinders

D01	12	F	M	4	0	0500	H	0	P	C
<b>Model:</b> <b>D01</b> Double acting pneumatic cylinder  <b>B01</b> Double acting pneumatic cylinder with piston rod lock, only up to ø 125 mm	<b>Piston ø</b> <b>03</b> = 32 <b>04</b> = 40 <b>05</b> = 50 <b>06</b> = 63 <b>08</b> = 80 <b>10</b> = 100 <b>12</b> = 125 <b>16</b> = 160 <b>20</b> = 200 <b>25</b> = 250 <b>32</b> = 320	<b>Product Line</b>	<b>M</b> =with magnetic piston <b>A</b> =without magnetic piston	<b>Ports:</b> <b>1</b> = 1/8" <b>2</b> = 1/4" <b>3</b> = 3/8" <b>4</b> = 1/2" <b>5</b> = 3/4" <b>6</b> = 1"	<b>Piston Rod Type:</b> <b>0</b> =C40 chrome-plated <b>C</b> =Inox AISI 303, chrome-plated <b>X</b> =Inox AISI 303, chrome-plated, double rod cylinder <b>P</b> =C40 chrome-plated, double rod cylinder <b>R</b> =Inox AISI 303, chrome-plated, double rod cylinder <b>W</b> =Inox AISI 303, double rod cylinder <b>T</b> =C40 chrome-plated, Tandem cylinder <b>A</b> =Inox AISI 303, chrome-plated, Tandem cylinder <b>Z</b> =Inox AISI 303, Tandem cylinder	<b>Stroke in mm</b>	<b>Seal:</b> <b>N</b> =Standard NBR 70 <b>H</b> =PUR 92° <b>V</b> =Viton (150°) <b>A</b> =low friction	<b>Construction:</b> <b>0</b> =Aluminium profile-tube <b>Z</b> =Aluminium tube with tie rods ø 250 and 320 mm only with tie rods <b>S</b> = Special, e.g. with bellows	<b>Piston rod mountings:</b> <b>0</b> =without <b>F</b> =Yokes with lockable pins <b>P</b> =Yokes with clevis pins <b>T</b> =Self lubricating rod ends <b>A</b> =Self-aligning joints	<b>Bottom mountings:</b> <b>0</b> =without <b>C</b> =Female hinge with pivot <b>D</b> =Female hinge <b>M</b> =Male hinge <b>H</b> =Articulated head <b>V</b> =Vertical rear hinge <b>Z</b> =Horizontal rear hinge <b>A</b> =Front flange <b>B</b> =Angle foot <b>G</b> =Rear flange <b>I</b> =Intermediate trunnion <b>R</b> =Adjustable intermediate trunnion <b>L</b> =Horizontal rear hinge for trunnion I+R

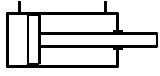
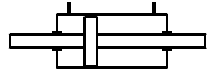
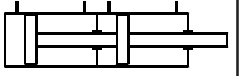

## Bestelldaten • Ordering data

### Pneumatikzylinder • Pneumatic cylinders

Kolbenstange • Piston Rod Type			
<b>WERKSTOFF • MATERIAL</b>	Zylinder mit Einzelstange, <i>Single rod cylinder,</i> (ø 32 - 320)	Mit durchgehender Kolbenstange, <i>Double rod cylinder,</i> (ø 32 - 200)	Tandem (ø 32-100)
Stahl C40 mit Chromauftrag <i>C40 Steel, chrome-plated</i>	<b>0</b>	<b>P</b>	<b>T</b>
Inox AISI 303 mit Chromauftrag <i>Chrome-plated</i>	<b>C</b>	<b>R</b>	<b>A</b>
Inox AISI 303	<b>X</b>	<b>W</b>	<b>Z</b>





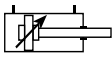
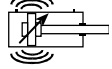
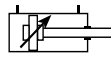
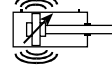



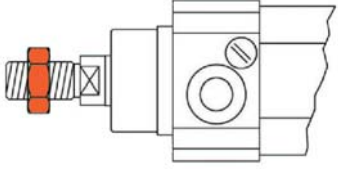
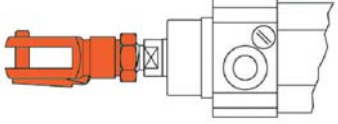
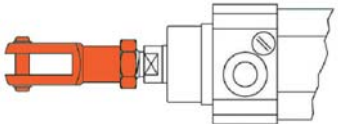
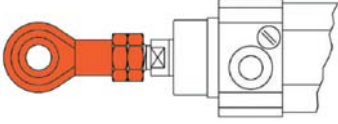
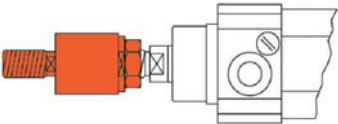

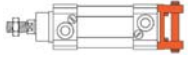
### Standardhübe • Standard Stroke

mm	25	50	75	80	100	125	150	160	200	250	300	320	350	400	450	500	600	700	800	900	1000
CODE	0025	0050	0075	0080	0100	0125	0150	0160	0200	0250	0300	0320	0350	0400	0450	0500	0600	0700	0800	0900	1000

		Typ "0"		Typ "Z"	
		Aluminiumprofilrohr ohne Zugstangen <i>Aluminium profile without tie-rods</i>		Aluminiumprofilrohr mit 4 Zugstangen <i>Aluminium profile with 4 tie-rods</i>	
					
<b>SERIE</b> <i>SERIES</i>	<b>DICHTUNGEN</b> <i>SEAL</i>				
<b>STANDARD</b>	NBR 70 (Buna N)	<b>"A"</b>	<b>"M"</b>	<b>"A"</b>	<b>"M"</b>
<b>HEAVY</b>	Pur Polyurethane 92° SHA				
<b>VIGOR</b>	VITON®				
<b>ACTION</b>	Reibungsarm <i>Low friction</i>				

## Bestelldaten • Ordering data

Erläuterungen Suffix	Befestigung Kolbenstange Piston Rod Mounting Options
(Standard) <b>0</b>	<b>Mutter</b> <i>Locknut</i> 
<b>F</b>	<b>Gabelköpfe mit Clips</b> <i>Yokes with lockable pins</i> 
<b>P</b>	<b>Gabelköpfe mit Bolzen</b> <i>Yokes with clevis pins</i> 
<b>T</b>	<b>Gelenkköpfe wartungsfrei</b> <i>Self-lubricating rod ends</i> 
<b>A</b>	<b>Flexokupplungen</b> <i>Self-aligning joints</i> 

Erläuterungen Suffix	Einbauvarianten Mounting Options
(Standard) <b>0</b>	<b>4+4 RT Gewinde</b> <i>4+4 RT thread</i> 
<b>C</b>	<b>Schwenkflansch mit Bolzen</b> <i>Female hinge with pivot</i> 
<b>D</b>	<b>Schwenkflansch "weiblich"</b> <i>Female hinge</i> 
<b>M</b>	<b>Schwenkflansch "männlich"</b> <i>Male hinge</i> 
<b>H</b>	<b>Schwenkflansch mit sphärischer Lagerung</b> <i>Articulated head</i> 
<b>V</b>	<b>Schwenklager mit Gegenlager</b> <i>Vertical rear hinge</i> 
<b>Z</b>	<b>Lagerbock</b> <i>Horizontal rear hinge</i> 
<b>A</b>	<b>Flansch kopfseitig</b> <i>Front flange</i> 
<b>B</b>	<b>Fußwinkel</b> <i>Angle foot</i> 
<b>G</b>	<b>Flansch bodenseitig</b> <i>Rear flange</i> 
<b>I</b>	<b>Schwenklager</b> <i>Intermediate trunnion</i> 
<b>R</b>	<b>Schwenklager regulierbar</b> <i>Adjustable intermediate trunnion</i> 

# Pneumatikzylinder • Pneumatic cylinders

VDMA 24562 • ISO 6431

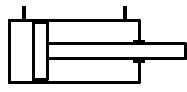
Zylinder mit Einzelstange		Single rod cylinder
Stahl C40 mit Chromauftrag	<b>0</b>	C40 steel, chrome-plated
AISI 303 mit Chromauftrag	<b>C</b>	AISI 303, chrome-plated
Inox AISI 303	<b>X</b>	Stainless steel, AISI 303

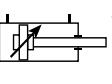
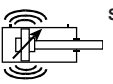

Aluminiumprofilrohr ohne Zugstangen Aluminium profile without tie-rods		STANDARD	HEAVY	VIGOR	ACTION		STANDARD	HEAVY	VIGOR	ACTION
		<b>N</b>	<b>H</b>	<b>V</b>	<b>A</b>		<b>N</b>	<b>H</b>	<b>V</b>	<b>A</b>

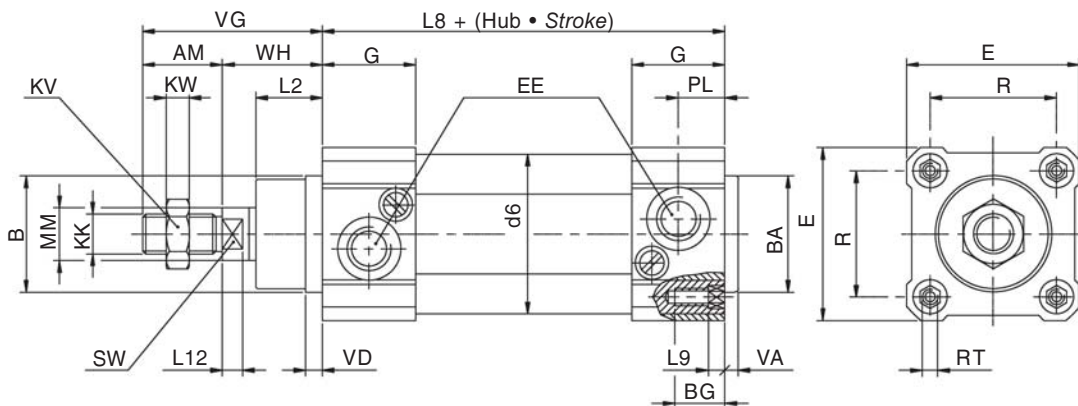

Code	ø mm	AM	e11 B ø	e11 BA ø	BG	d6	E	EE	G	L2	L8	L9	L12	KK	KV	KW	MM ø	PL	R	RT	SW	VA	VD	VG	WH	Gewicht, Weight	
																										0mm g	1mm g/mm
D0103F	32	22	30	30	16,2	36,5	47	G 1/8	26,5	17,5	94	5,0	6	M10x1,25	17	6	12	13	32,5	M6	10	4	5	48	26	553	2,26
D0104F	40	24	35	35	16,2	45,0	52	G 1/4	28,0	20,0	105	5,0	7	M12x1,25	19	7	16	14	38,0	M6	12	4	5	54	30	825	3,20
D0105F	50	32	40	40	19,5	55,5	65	G 1/4	28,0	25,0	106	6,0	9	M16x1,5	24	8	20	14	46,5	M8	17	4	5	69	37	1335	4,66
D0106F	63	32	45	45	19,5	68,0	75	G 3/8	35,0	25,0	121	6,0	9	M16x1,5	24	8	20	20	56,5	M8	17	4	5	69	37	2000	5,10
D0108F	80	40	45	45	20,5	86,5	95	G 3/8	34,0	33,0	128	8,5	10	M20x1,5	30	9	25	18	72,0	M10	22	4	5	86	46	3245	7,45
D0110F	100	40	55	55	20,5	108	115	G 1/2	38,0	38,0	138	8,5	10	M20x1,5	30	9	25	20	89,0	M10	22	4	5	91	51	5000	8,70
D0112FM	125	54	60	60	20,0	133	140	G 1/2	45	50	160	6,0	13	M27x2,0	41	12	32	30	110	M12	27	5	6	119	65	6400	13,40
D0116FM	160	72	65	65	24,0	171	180	G 3/4	49	50	180	-	16	M36x2,0	55	14	40	28	140	M16	36	5	6	152	80	12600	26,33
D0120FM	200	72	75	75	24,0	212	220	G 3/4	49	60	180	-	16	M36x2,0	55	14	40	28	175	M16	36	5	6	167	95	16100	31,00

# Pneumatikzylinder • Pneumatic cylinders

VDMA 24562 • ISO 6431

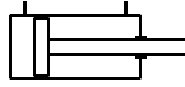

Zylinder mit Einzelstange		Single rod cylinder
Stahl C40 mit Chromauftrag	<b>0</b>	C40 steel, chrome-plated
AISI 303 mit Chromauftrag	<b>C</b>	AISI 303, chrome-plated
Inox AISI 303	<b>X</b>	Stainless steel, AISI 303



Aluminiumprofilrohr mit 4 Zugstangen Aluminium profile with 4 tie-rods	STANDARD HEAVY VIGOR ACTION				STANDARD HEAVY VIGOR ACTION			
	N	H	V	A	N	H	V	A

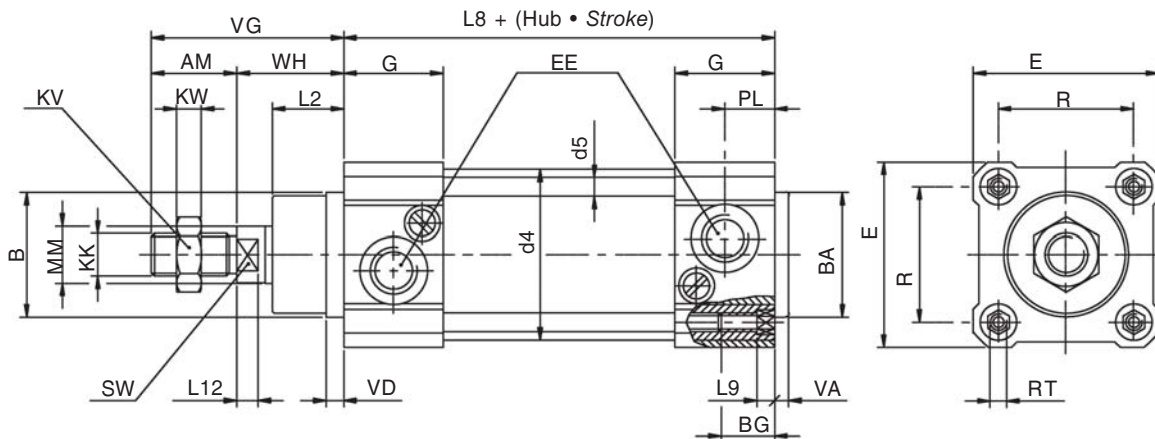



Code	ø	AM	B	e11 ø	e11 ø	BA	BG	d4	d5	E	EE	G	L2	L8	L9	L12	KK	KV	KW	MM	PL	R	RT	SW	VA	VD	VG	WH	Gewicht, Weight	
																													0mm g	1mm g/mm
D0103F	32	22	30	30	16,2	36	6	47	G 1/8	26,5	17,5	94	5	6	M10x1,25	17	6	12	13	32,5	M6	10	4	5	48	26	553	2,26		
D0104F	40	24	35	35	16,2	45	6	52	G 1/4	28	20	105	5	7	M12x1,25	19	7	16	14	38,0	M6	12	4	5	54	30	825	3,20		
D0105F	50	32	40	40	19,5	55	8	65	G 1/4	28	25	106	6	9	M16x1,5	24	8	20	14	46,5	M8	17	4	5	69	37	1335	4,66		
D0106F	63	32	45	45	19,5	68	8	75	G 3/8	35	25	121	6	9	M16x1,5	24	8	20	20	56,5	M8	17	4	5	69	37	2000	5,10		
D0108F	80	40	45	45	20,5	86	10	95	G 3/8	34	33	128	8,5	10	M20x1,5	30	9	25	18	72,0	M10	22	4	5	86	46	3245	7,45		
D0110F	100	40	55	55	20,5	105	10	115	G 1/2	38	38	138	8,5	10	M20x1,5	30	9	25	20	89,0	M10	22	4	5	91	51	5000	8,70		
D0112FM	125	54	60	60	20,0	132	12	240	G 1/2	45	50	160	6	13	M27x2	41	12	32	30	110	M12	27	5	6	119	65	6650	13,70		
D0116FM	160	72	65	65	24,0	167	16	160	G 3/4	49	50	180	-	16	M36x2	55	14	40	28	140	M16	36	5	6	152	80	12200	21,05		
D0120FM	200	72	75	75	24,0	210	16	220	G 3/4	49	60	180	-	16	M36x2	55	14	40	28	175	M16	36	5	6	167	95	15600	24,90		
D0125FM	250	84	90 <sub>d11</sub>	90	25	240	20	275	G 1	55	65	200	-	20	M42x2	60	21	50	32	220	M20	46	10	-	189	105	34000	47,00		
D0132FM	320	96	110 <sub>d11</sub>	110	28	294	24	345	G 1	58	75	220	-	24	M48x2	65	25	63	32	270	M24	55	10	-	216	120	58000	60,00		



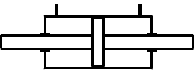

# Pneumatikzylinder • Pneumatic cylinders

## VDMA 24562 • ISO 6431

Mit durchgehender Kolbenstange		Double rod cylinder
Stahl C40 mit Chromauftrag	<b>P</b>	C40 steel, chrome-plated
AISI 303 mit Chromauftrag	<b>R</b>	AISI 303, chrome-plated
Inox AISI 303	<b>W</b>	Stainless steel, AISI 303

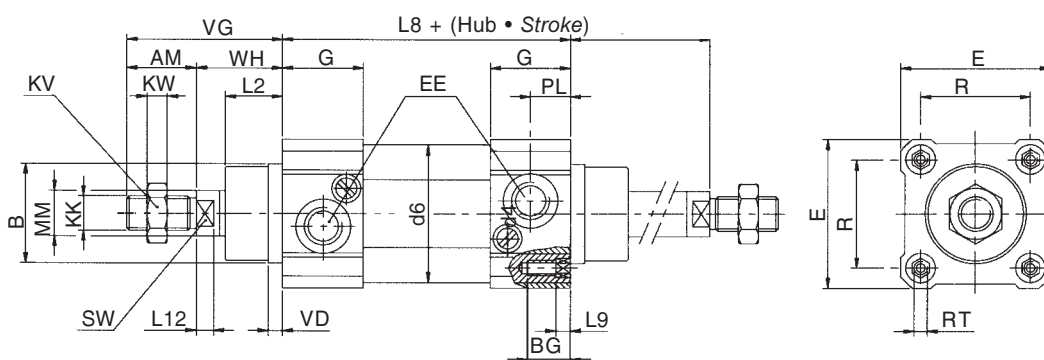
Aluminiumprofilrohr ohne Zugstangen Aluminium profile without tie-rods		STANDARD HEAVY VIGOR ACTION					STANDARD HEAVY VIGOR ACTION			
		<b>N</b>	<b>H</b>	<b>V</b>	<b>A</b>		<b>N</b>	<b>H</b>	<b>V</b>	<b>A</b>



Aluminiumprofilrohr mit 4 Zugstangen Aluminium profile with 4 tie-rods		STANDARD HEAVY VIGOR ACTION					STANDARD HEAVY VIGOR ACTION			
		<b>N</b>	<b>H</b>	<b>V</b>	<b>A</b>		<b>N</b>	<b>H</b>	<b>V</b>	<b>A</b>

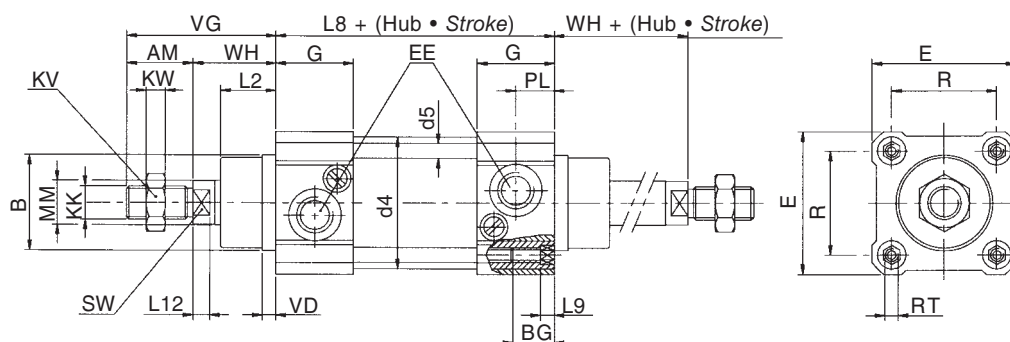

Code	ø mm	AM ø	B ø	BG ø	d4 ø	d5 ø	d6	E	EE	G	L2	L8	L9	L12	KK	KV	KW ø	MM	PL	R	RT	SW	VD	VG	WH	Gewicht, Weight	
																										0mm g	1mm g/mm
D0103F	32	22	30	16,2	36	6	36,5	47	G 1/8	26,5	17,5	94	5	6	M10x1,25	17	6	12	13	32,5	M6	10	5	48	26	563	3,20
D0104F	40	24	35	16,2	45	6	45,0	52	G 1/4	28	20	105	5	7	M12x1,25	19	7	16	14	38,0	M6	12	5	54	30	840	4,80
D0105F	50	32	40	19,5	55	8	55,0	65	G 1/4	28	25	106	6	9	M16x1,5	24	8	20	14	46,5	M8	17	5	69	37	1363	7,20
D0106F	63	32	45	19,5	68	8	68,0	75	G 3/8	35	25	121	6	9	M16x1,5	24	8	20	20	56,5	M8	17	5	69	37	2040	7,50
D0108F	80	40	45	20,5	86	10	86,5	95	G 3/8	34	33	128	8,5	10	M20x1,5	30	9	25	18	72,0	M10	22	5	86	46	3300	11,40
D0110F	100	40	55	20,5	105	10	108	115	G 1/2	38	38	138	8,5	10	M20x1,5	30	9	25	20	89,0	M10	22	5	91	51	5060	12,60
D0112FM	125	54	60	20,0	132	12	133	140	G 1/2	45	50	160	6	13	M27x2	41	12	32	30	110	M12	27	6	119	65	7200	19,80
D0116FM	160	72	65	24,0	167	16	171	160	G 3/4	49	50	180	-	16	M36x2	55	14	40	28	140	M16	36	6	152	80	14000	32,00
D0120FM	200	72	75	24,0	210	16	212	220	G 3/4	49	60	180	-	16	M36x2	55	14	40	28	175	M16	36	6	167	95	17700	35,00

# Pneumatikzylinder • Pneumatic cylinders

## VDMA 24562 • ISO 6431

Tandem		Tandem
Stahl C40 mit Chromauftrag	<b>T</b>	C40 steel, chrome-plated
AISI 303 mit Chromauftrag	<b>A</b>	AISI 303, chrome-plated
Inox AISI 303	<b>Z</b>	Stainless steel, AISI 303

Aluminiumprofilrohr ohne Zugstangen Aluminium profile without tie-rods	STANDARD HEAVY VIGOR ACTION				STANDARD HEAVY VIGOR ACTION			
		<b>N</b>	<b>H</b>	<b>V</b>	<b>A</b>	<b>N</b>	<b>H</b>	<b>V</b>

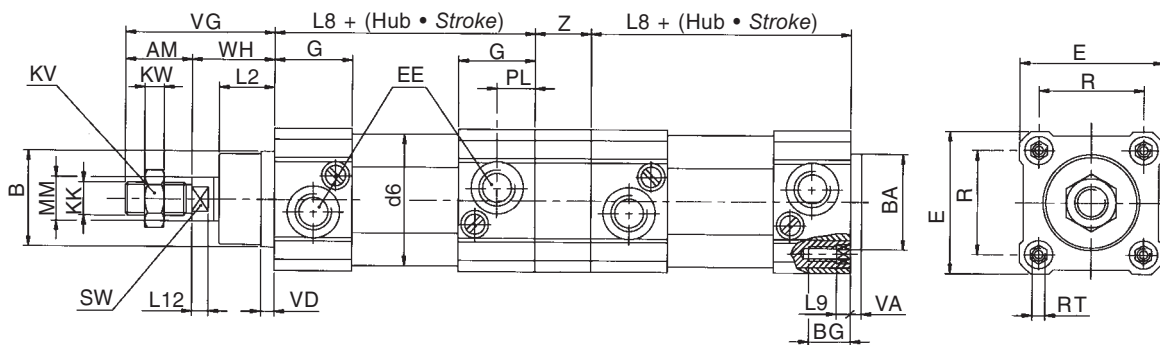

Aluminiumprofilrohr mit 4 Zugstangen Aluminium profile with 4 tie-rods	STANDARD HEAVY VIGOR ACTION				STANDARD HEAVY VIGOR ACTION			
		<b>N</b>	<b>H</b>	<b>V</b>	<b>A</b>	<b>N</b>	<b>H</b>	<b>V</b>

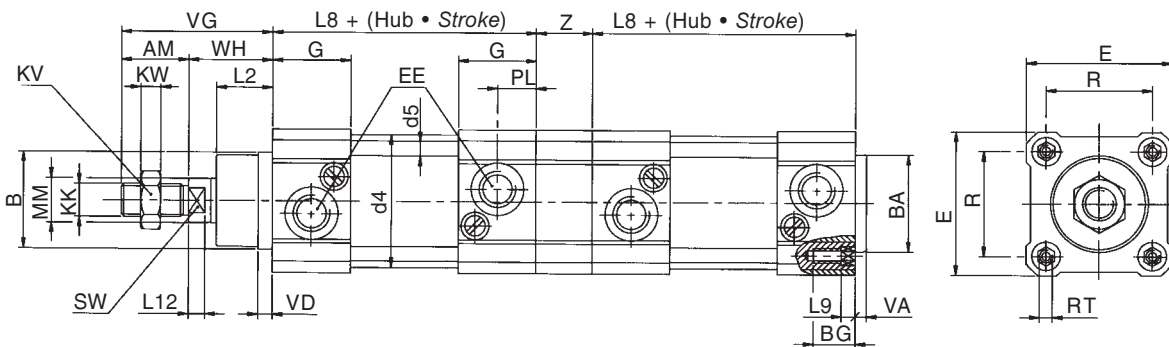

Code	ø mm	AM ø	B ø	e11 BA ø	BG ø	d4 ø	d5 ø	d6	E	EE	G	L2	L8	L9	L12	KK	KV	KW	MM ø	PL	R	RT	SW	VA	VD	VG	WH	Z	Gewicht, Weight	
																													0mm g	1mm g/mm
D0103F	32	22	30	30	16,2	36	6	36,5	47	G 1/8	26,5	17,5	94	5,0	6	M10x1,25	17	6	12	13	32,5	M6	10	4	5	48	26	25	1150	5,0
D0104F	40	24	35	35	16,2	45	6	45,0	52	G 1/4	28	20	105	5,0	7	M12x1,25	19	7	16	14	38,0	M6	12	4	5	54	30	30	1650	7,0
D0105F	50	32	40	40	19,5	55	8	55,0	65	G 1/4	28	25	106	6,0	9	M16x1,5	24	8	20	14	46,5	M8	17	4	5	69	37	40	2700	9,5
D0106F	63	32	45	45	19,5	68	8	68,0	75	G 3/8	35	25	121	6,0	9	M16x1,5	24	8	20	20	56,5	M8	17	4	5	69	37	40	4050	10,4
D0108F	80	40	45	45	20,5	86	10	86,5	95	G 3/8	34	33	128	8,5	10	M20x1,5	30	9	25	18	72,0	M10	22	4	5	86	46	50	6500	15
D0110F	100	40	55	55	20,5	105	10	108	115	G 1/2	38	38	138	8,5	10	M20x1,5	30	9	25	20	89,0	M10	22	4	5	91	51	50	10100	18,0

# Theoretische Zylinderkräfte • Theoretical cylinder thrust

Antriebe in der Theorie, Vor- und Rückhub. Folgendermaßen werden die theoretischen Antriebsgrundlagen der Zylinder dargestellt. Berechnet wird sowohl im ausgefahrenen, als auch im eingefahrenen Zustand; es wird von 100 % ( $\mu = 1$ ) Wirkungsgrad ausgegangen. Zur richtigen Auswahl des Zylinders sind drei Faktoren zu beachten:

1. Die erforderliche **Kraft (F)** des Zylinders gemessen in Newton.
2. Der **Druck (P)** des Zylinders gemessen in bar.
3. **Kolbenfläche (A)** in  $\text{cm}^2$ .

Es gilt folgende Formel:

**Kraft = Druck • Fläche • Wirkungsgrad**

$$F = P \cdot A \cdot 10 \cdot \mu$$

Assuming 100 % efficiency ( $\mu = 1$ ), the following expression gives the cylinder thrust both in extension and retraction. In order to choose the correct cylinder, the following factors must be taken into account:

1. The **Force (F)** developed by the cylinder in Newton.
2. The **Pressure (P)** supplied to the cylinder in bar.
3. **Piston Area (A)** in  $\text{cm}^2$ .

The calculation is as follows:

**Force = Pressure • Area • Efficiency**

$$F = P \cdot A \cdot 10 \cdot \mu$$

### IMPORTANT:

For our cylinders, an efficiency of 85 % should be used ( $\mu = 0.85$ ).

### ACHTUNG:

Der empfohlene Wirkungsgrad unserer Zylinder entspricht 85 % ( $\mu = 0,85$ ).











### Doppeltwirkende Zylinder • Double Acting Cylinder

ø mm		bar									
		1	2	3	4	5	6	7	8	9	10
32		80	161	241	321	402	482	562	643	723	804
		69	138	207	276	345	414	483	553	622	691
40		126	251	377	502	628	753	879	1005	1130	1256
		105	211	316	422	527	633	738	844	949	1055
50		196	392	589	785	981	1177	1374	1570	1766	1962
		165	330	494	659	824	989	1154	1319	1484	1648
63		312	623	935	1246	1558	1869	2181	2492	2804	3115
		280	560	840	1120	1401	1681	1961	2241	2521	2801
80		502	1005	1507	2010	2512	3014	3517	4019	4522	5024
		453	907	1360	1813	2267	2720	3173	3627	4080	4533
100		785	1510	2355	3140	3925	4710	5495	6280	7065	7850
		736	1472	2208	2944	3680	4415	5152	5887	6623	7359
125		1226	2452	3678	4904	6130	7356	8582	9808	11034	12260
		1146	2292	3438	4584	5730	6876	8022	9168	10314	11460
160		2009	4018	6027	8036	10045	12054	14063	16072	18081	20090
		1851	3702	5553	7404	9255	11106	12957	14808	16659	18510
200		3140	6280	9420	12560	15700	18840	21980	25120	28260	31400
		3014	6029	9043	12058	15072	18086	21101	24115	27130	30144
250		4906	9812	14718	19624	24530	29436	34342	39248	44154	49060
		4709	9418	14127	18836	23545	28254	32963	37672	42381	47090
320		8038	16076	24114	32152	40190	48228	56266	64304	72342	80380
		7727	15454	23181	30908	38635	46362	54089	61816	69543	77270













(Newton)

## Theoretische Zylinderkräfte • Theoretical cylinder thrust

Mit durchgehender Kolbenstange • Double rod cylinder

ø mm		bar										(Newton)
		1	2	3	4	5	6	7	8	9	10	
32		69	138	207	276	345	414	483	552	622	691	
40		105	211	316	422	527	633	738	844	949	1055	
50		165	330	494	659	824	989	1154	1320	1484	1648	
63		280	560	840	1120	1400	1681	1961	2241	2521	2801	
80		453	907	1360	1813	2267	2720	3173	3627	4080	4533	
100		736	1472	2208	2944	3680	4415	5152	5887	6623	7359	
125		1146	2292	3438	4584	5730	6876	8022	9168	10314	11460	
160		1851	3702	5553	7404	9255	11106	12957	14808	16659	18510	
200		3014	6029	9043	12058	15072	18086	21101	24115	27130	30144	

Tandem

ø mm		bar										(Newton)
		1	2	3	4	5	6	7	8	9	10	
32		<b>149</b>	<b>299</b>	<b>448</b>	<b>598</b>	<b>747</b>	<b>896</b>	<b>1046</b>	<b>1195</b>	<b>1345</b>	<b>1495</b>	
		138	276	414	552	691	829	967	1105	1243	1382	
40		<b>231</b>	<b>462</b>	<b>693</b>	<b>924</b>	<b>1155</b>	<b>1386</b>	<b>1618</b>	<b>1849</b>	<b>2080</b>	<b>2311</b>	
		211	422	633	844	1055	1266	1477	1688	1899	2110	
50		<b>361</b>	<b>722</b>	<b>1083</b>	<b>1444</b>	<b>1805</b>	<b>2166</b>	<b>2528</b>	<b>2889</b>	<b>3250</b>	<b>3611</b>	
		240	659	989	1319	1648	1978	2308	2637	2967	3297	
63		<b>592</b>	<b>1183</b>	<b>1775</b>	<b>2367</b>	<b>2958</b>	<b>3550</b>	<b>4142</b>	<b>4734</b>	<b>5325</b>	<b>5917</b>	
		560	1120	1681	2241	2801	3362	3922	4482	5043	5603	
80		<b>956</b>	<b>1911</b>	<b>2867</b>	<b>3823</b>	<b>4778</b>	<b>5734</b>	<b>6690</b>	<b>7646</b>	<b>8601</b>	<b>9557</b>	
		907	1813	2720	3627	4533	5440	6347	7253	8160	9067	
100		<b>1521</b>	<b>3041</b>	<b>4563</b>	<b>6084</b>	<b>7605</b>	<b>9125</b>	<b>10646</b>	<b>12167</b>	<b>13688</b>	<b>15209</b>	
		1472	2944	4415	5887	7359	8831	10303	11775	13247	14719	

## Sonderversionen • *Special models*

Alle Zylinder der Serien "Standard", "Heavy", "Vigor" und "Action" sind auf Wunsch in folgenden Sonderversionen lieferbar:

- **Mit Zwischenhublängen** von 25 bis 1000 mm in 5 mm Schritten.
- **Mit Sonderhublängen** bis 3000 mm.
- **Einfachwirkend mit Feder**, deckel- oder bodenseitig, auch mit Magnetkolben lieferbar.
- **Für die Lebensmittelindustrie** Kolbenstange, Schrauben oder Zugstangen, Seegerringe und Endlagendämpfung aus Edelstahl AISI 316. Enddeckel und Rohr aus eloxiertem Aluminium.

All "Standard", "Heavy", "Vigor" and "Action" series cylinders can be supplied on request in the following special versions:

- 25 through 1000 mm **intermediate stroke**
- Up to 3000 mm **extended stroke**
- **Single action**, normally retracted or extended with/without magnetic piston
- **Food industry applications**: rod, sockets or tie rods, cushion screws and circlips in 316 AISI stainless steel. Endcaps and barrel in anodised aluminium as per standard version.

**Mit Doppelkolben für drei Stellungen**

*Double piston rod with three positions*

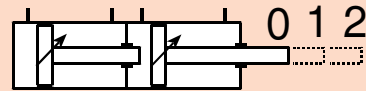

**Mit gegenüberliegenden Kolbenstangen**

*Double piston, back to back*

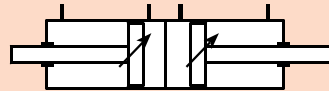

Lieferbar sind außerdem Sonderausführungen nach Kundenwunsch, unsere technische Abteilung steht für alle Anfragen gerne zur Verfügung.

*Customer-specific cylinder versions are also available; please contact our engineering department.*

### Sonderhublängen • *Special Stroke*

mm

von / from **1000**

bis / to **3000**

## Befestigung Kolbenstange • Piston rod mounting

### STANDARD Mutter Nut

0

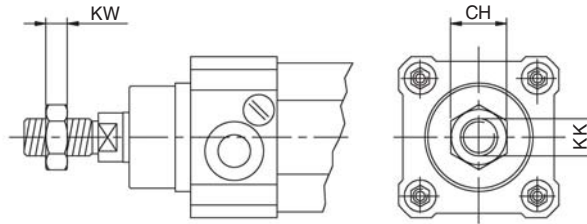

ø mm	KK	KW	CH
32	M10x1,25	6	17
40	M12x1,25	7	19
50	M16x1,5	9	24
63	M16x1,5	9	24
80	M20x1,5	10	30
100	M20x1,5	10	30
125	M27x2	12	41
160	M36x2	14	55
200	M36x2	14	55
250	M42x2	21	60
320	M48x2	25	65

### Zur separaten Bestellung To be ordered separately

113C38
114C38
115C38
115C38
116C38
116C38
126C38
118C38
118C38
119C38
120C38

### Gabelköpfe mit Clips

Yokes with lockable  
pins

F

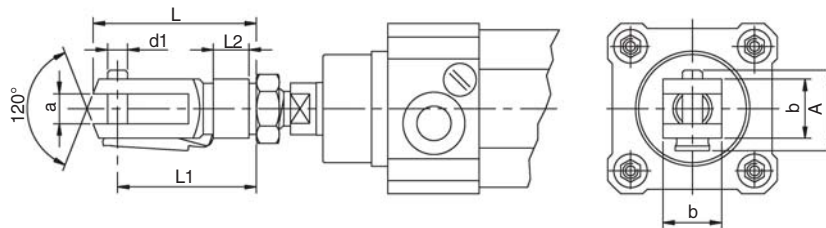

ø mm	L	L1	L2	ø d1	a	b	A
32	52	40	10	10	10	20	26
40	62	48	12	12	12	24	32
50	83	64	15	16	16	32	38
63	83	64	15	16	16	32	38
80	105	80	16	20	20	40	48
100	105	80	16	20	20	40	48

### Zur separaten Bestellung To be ordered separately

D0103FA0008
D0104FA0008
D0105FA0008
D0105FA0008
D0108FA0008
D0108FA0008

### Gabelköpfe mit Bolzen

Yokes with clevis  
pins

P

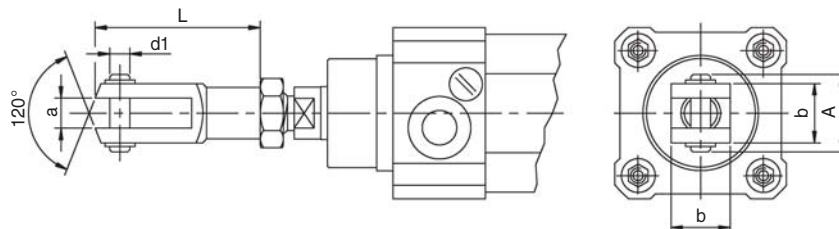

ø mm	L	ø d1	a	b	A
32	52	10 h8	10	20	25
40	62	12 h8	12	24	30
50	83	16 h8	16	32	39
63	83	16 h8	16	32	39
80	105	20 h8	20	40	48
100	105	20 h8	20	40	48
125	148	30 h8	30	55	65
160	188	35 h8	35	70	84
200	188	35 h8	35	70	84
250	210	40 h7	40	80	106
320	260	50 h7	50	100	121

### Zur separaten Bestellung To be ordered separately

D0103FA0005
D0104FA0005
D0105FA0005
D0105FA0005
D0108FA0005
D0108FA0005
D0112FA0005
D0116FA0005
D0120FA0005
D0125C0005
D0132C0005

## Befestigung Kolbenstange • Piston rod mounting

Gelenkköpfe,  
wartungsfrei  
Self-lubricating  
rod ends

DIN 648-K

T

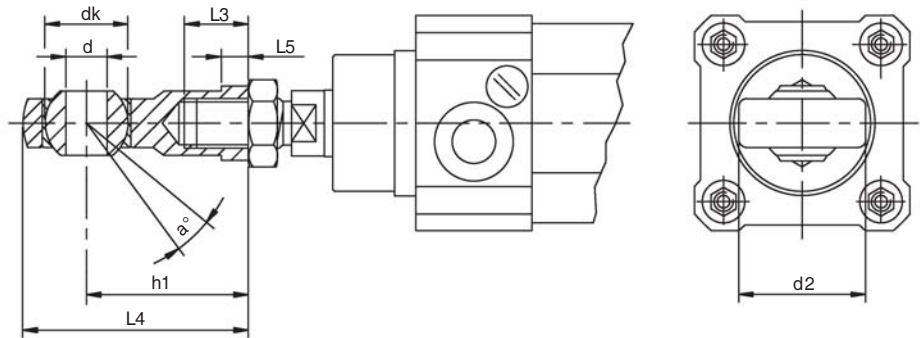

ø mm	L3	L4	L5	ø d	ø dk	α°	h1	d2
32	20	57	6,5	10	19,050	13	43	28
40	22	66	6,5	12	22,225	13	50	32
50	28	85	8	16	28,575	15	64	42
63	28	85	8	16	28,575	15	64	42
80	33	102	10	20	34,925	14	77	50
100	33	102	10	20	34,925	14	77	50
125	51	145	15	30	50,800	17	110	70
160	56	165	17	35	57,150	19	125	80
200	56	165	17	35	57,150	19	125	80
250	60	188	-	40	-	17	142	92
320	65	216	-	50	-	12	160	112

Zur separaten Bestellung  
To be ordered separately

D0103FA0006  
D0104FA0006  
D0105FA0006  
D0105FA0006  
D0108FA0006  
D0108FA0006  
D0112FA0006  
D0116FA0006  
D0120FA0006  
D0125C0006  
D0132C0006

Flexkupplungen  
Self-aligning joints

A

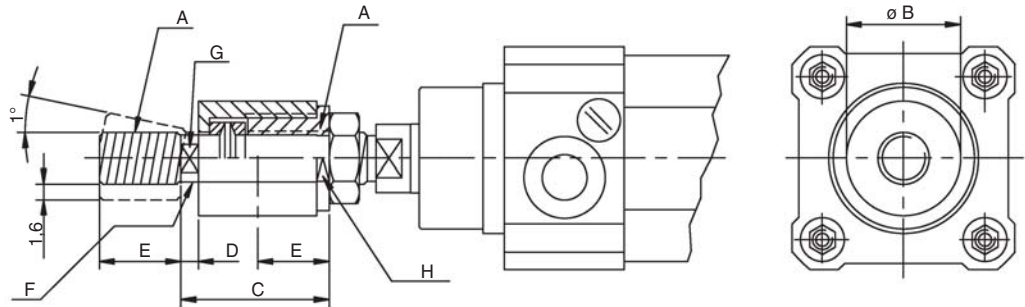

ø mm	A	ø B	C	D	E	ø F	G	H
32	M10x1,25	22	32	6.5	20	8	7	19
40	M12x1,25	32	51,5	13	24	16	13	27
50	M16x1,5	32	51,5	13	32	16	13	27
63	M16x1,5	32	51,5	13	32	16	13	27
80	M20x1,5	44	60	12	40	24,5	19	36
100	M20x1,5	44	60	12	40	24,5	19	36
125	-	-	-	-	-	-	-	-
160	M36x2	82	111	21	72	44,5	36	65
200	M36x2	82	111	21	72	44,5	36	65

Zur separaten Bestellung  
To be ordered separately

D0103FA0012  
D0104FA0012  
D0105FA0012  
D0105FA0012  
D0108FA0012  
D0108FA0012  
-  
D0116FA0012  
D0120FA0012

## Einbauvarianten • Mounting options

**STANDARD**  
4+4 RT Gewinde  
4+4 RT thread

**0**

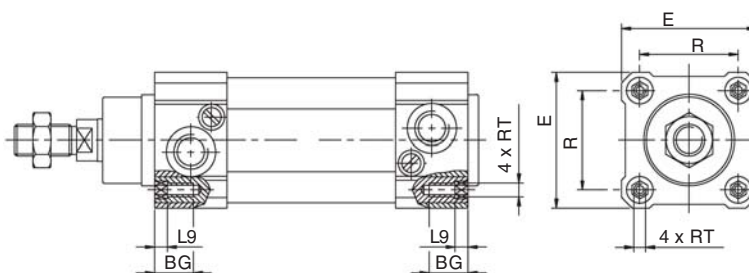

ø mm	RT	BG	L9	E	R
32	M6	16,2	5	47	32,5
40	M6	16,2	5	52	38
50	M8	18,2	6	65	46,5
63	M8	18,2	6	75	56,5
80	M10	20,5	8,5	95	72
100	M10	20,5	8,5	115	89
125	M12	20	6	140	110
160	M16	24	-	180	140
200	M16	24	-	220	175
250	M20	25	-	275	220
320	M24	28	-	345	270

**Schwenkflansch mit Bolzen**  
Female hinge with pivot

**C**

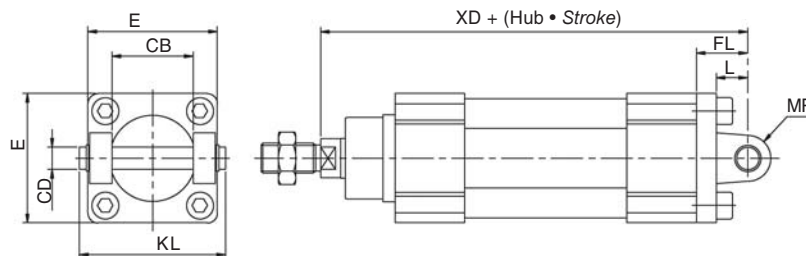

ø mm	CB	ø CD <sub>h9</sub>	E	FL	KL	L	MR	XD
32	26	10	45	22	53	12	11	142
40	28	12	52	25	60	15	13	160
50	32	12	65	27	69	15	13	170
63	40	16	75	32	80	20	17	190
80	50	16	95	36	101	20	17	210
100	60	20	115	41	121	25	21	230
125	70	25	140	50	142	30	26	275
160	90	30	180	55	184	35	31	315
200	90	30	220	60	228	35	31	335
250	110	40	275	70	200	40	41	375
320	120	45	345	75	200	45	46	420

Zur separaten Bestellung  
To be ordered separately

D0103FA0003  
D0104FA0003  
D0105FA0003  
D0106FA0003  
D0108FA0003  
D0110FA0003  
D0112FA0003  
D0116FA0003  
D0120FA0003  
D0125C0003  
D0132C0003

**Schwenkflansch, "weiblich"**  
Female hinge

**D**

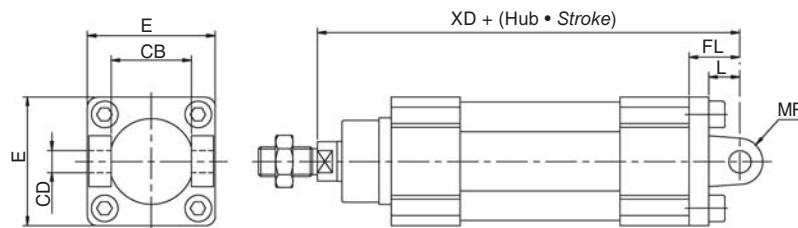

ø mm	CB	ø CD	E	FL	L	MR	XD
32	26	10	45	22	12	11	142
40	28	12	52	25	15	13	160
50	32	12	65	27	15	13	170
63	40	16	75	32	20	17	190
80	50	16	95	36	20	17	210
100	60	20	115	41	25	21	230
125	70	25	140	50	30	26	275
160	90	30	180	55	35	31	315
200	90	30	220	60	35	31	335

Zur separaten Bestellung  
To be ordered separately

D0103FA0013  
D0104FA0013  
D0105FA0013  
D0106FA0013  
D0108FA0013  
D0110FA0013  
D0112FA0013  
D0116FA0013  
D0120FA0013



## Einbauvarianten • Mounting options

Schwenkflansch,  
"männlich"  
Male hinge

**M**

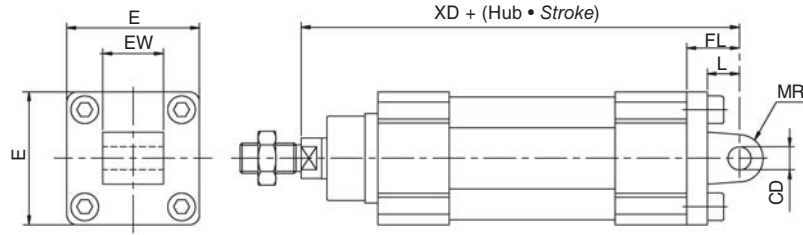

ø mm	ø CD	E	EW	FL	L	MR	XD
32	10	45	26	22	12	11	142
40	12	52	28	25	15	13	160
50	12	65	32	27	15	13	170
63	16	75	40	32	20	17	190
80	16	95	50	36	20	17	210
100	20	115	60	41	25	21	230
125	25	140	70	50	30	26	275
160	30	180	90	55	35	31	315
200	30	220	90	60	35	31	335
250	40	275	110	70	40	41	375
320	45	345	120	75	45	46	420

Zur separaten Bestellung To be ordered separately	
D0103FA0014	
D0104FA0014	
D0105FA0014	
D0106FA0014	
D0108FA0014	
D0110FA0014	
D0112FA0014	
D0116FA0014	
D0120FA0014	
D0125C0014	
D0132C0014	

Schwenkflansch  
mit sphärischer  
Lagerung  
Articulated head

**H**

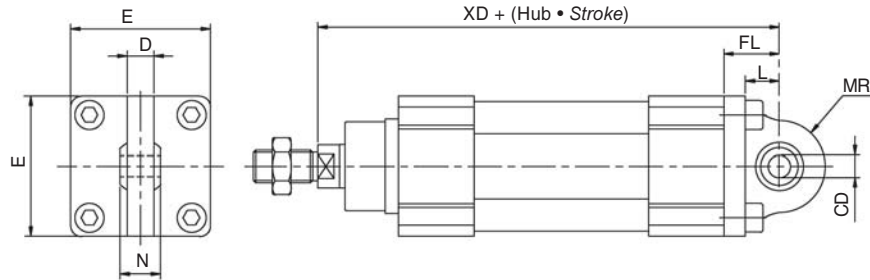

ø mm	ø CD	D	E	FL	L	N	MR	XD
32	10	10	45	22	12	14	16	142
40	12	12	52	25	15	16	19	160
50	12	12	65	27	15	16	19	170
63	16	15	75	32	20	21	24	190
80	16	15	95	36	20	21	24	210
100	20	18	115	41	25	25	30	230
125	25	22	140	50	30	31	36	275
160	30	25	180	55	35	37	36	315
200	30	25	220	60	35	37	36	335

Zur separaten Bestellung To be ordered separately	
D0103FA0015	
D0104FA0015	
D0105FA0015	
D0106FA0015	
D0108FA0015	
D0110FA0015	
D0112FA0015	
D0116FA0015	
D0120FA0015	

Schwenkflansch  
mit Gegenlager  
Vertical rear hinge

**V**

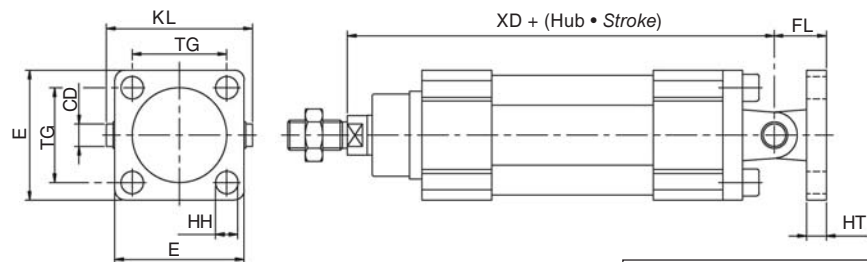

ø mm	ø CD	E	FL	ø HH	HT	KL	TG	XD
32	10	45	22	7	10	53	32,5	142
40	12	52	25	7	10	60	38	160
50	12	65	27	9	12	69	46,5	170
63	16	75	32	9	12	80	56,5	190
80	16	95	36	11	16	101	72	210
100	20	115	41	11	16	121	89	230
125	25	140	50	14	20	142	110	275
160	30	180	55	18	20	184	140	315
200	30	220	60	18	25	228	175	335

Zur separaten Bestellung To be ordered separately	
D0103FA0016	
D0104FA0016	
D0105FA0016	
D0106FA0016	
D0108FA0016	
D0110FA0016	
D0112FA0016	
D0116FA0016	
D0120FA0016	

## Einbauvarianten • Mounting options

**Flansch,  
kopfseitig**  
*Front flange*

**A**

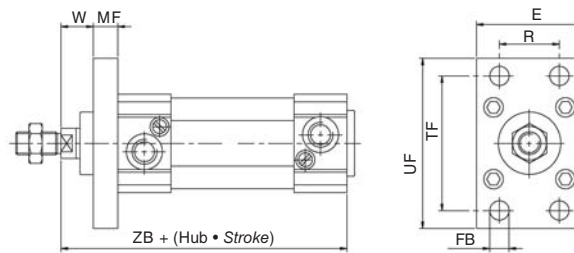

ø mm	E	ø FB	MF	R	TF	UF	W	ZB
32	50	7	10	32	64	80	16	120
40	55	9	10	36	72	90	20	135
50	65	9	12	45	90	110	25	143
63	75	9	12	50	100	120	25	158
80	95	12	16	63	126	153	30	174
100	115	14	16	75	150	178	35	189
125	140	16	20	90	180	220	45	225
160	180	18	20	115	230	270	60	260
200	225	22	25	135	270	312	70	275
250	275	25	25	165	330	395	80	320
320	345	30	30	200	400	475	90	355

**Zur separaten Bestellung**  
*To be ordered separately*

D0103FA0002
D0104FA0002
D0105FA0002
D0106FA0002
D0108FA0002
D0110FA0002
D0112FA0002
D0116FA0002
D0120FA0002
D0125C0002
D0132C0002

**Flansch,  
bodenseitig**  
*Rear flange*

**G**

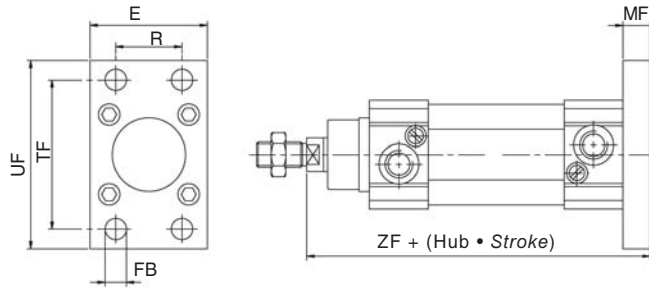

ø mm	E	ø FB	MF	R	TF	UF	ZF
32	50	7	10	32	64	80	130
40	55	9	10	36	72	90	145
50	65	9	12	45	90	110	155
63	75	9	12	50	100	120	170
80	95	12	16	63	126	153	190
100	115	14	16	75	150	178	205
125	140	16	20	90	180	220	245
160	180	18	20	115	230	270	280
200	225	22	25	135	270	312	300
250	275	25	25	165	330	395	330
320	345	30	30	200	400	475	370

**Zur separaten Bestellung**  
*To be ordered separately*

D0103FA0002
D0104FA0002
D0105FA0002
D0106FA0002
D0108FA0002
D0110FA0002
D0112FA0002
D0116FA0002
D0120FA0002
D0125C0002
D0132C0002

**Lagerbock**  
*Horizontal rear hinge*

**Z**

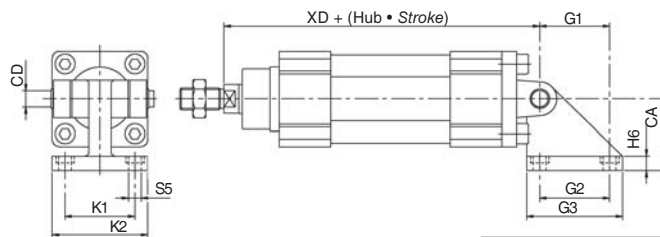

ø mm	CA	ø CD	G1	G2	G3	H6	K1	K2	ø S5	XD
32	32	10	21	18	31	8	38	51	6,6	142
40	36	12	24	22	35	10	41	54	6,6	160
50	45	12	33	30	45	12	50	65	9	170
63	50	16	37	35	50	12	52	67	9	190
80	63	16	47	40	60	14	66	86	11	210
100	71	20	55	50	70	15	76	96	11	230
125	90	25	70	60	90	20	94	124	14	275
160	115	30	97	88	126	25	118	156	14	315
200	135	30	105	90	130	30	122	162	18	335
250	165	40	128	110	160	35	150	200	22	375
320	200	45	150	122	186	40	170	234	26	420

**Zur separaten Bestellung**  
*To be ordered separately*

D0103C0007
D0104C0007
D0105C0007
D0106C0007
D0108C0007
D0110C0007
D0112C0007
D0116C0007
D0120C0007
D0125C0007
D0132C0007

# Einbauvarianten • Mounting options

**Schwenklager**  
Intermediate  
trunnion

**I**

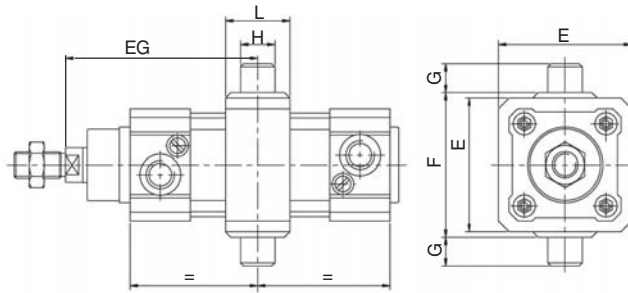

ø mm	E	F	G	ø H	L	EG
32	46	50	12	12	20	-
40	58	63	16	16	20	-
50	68	73	16	16	20	-
63	84	90	20	20	30	-
80	102	108	20	20	30	-
100	124	131	25	25	30	-
125	152	159	25	25	30	-
160	190	198	32	32	40	-
200	240	248	32	32	40	-
250	280	320	40	40	55	205
320	344	400	50	50	70	230

Zur separaten Bestellung  
To be ordered separately

D0103FA0010
D0104FA0010
D0105FA0010
D0106FA0010
D0108FA0010
D0110FA0010
D0112FA0010
D0116FA0010
D0120FA0010
D0125C0010
D0132C0010

**Schwenkflansch, regulierbar**

Adjustable  
intermediate  
trunnion

**R**

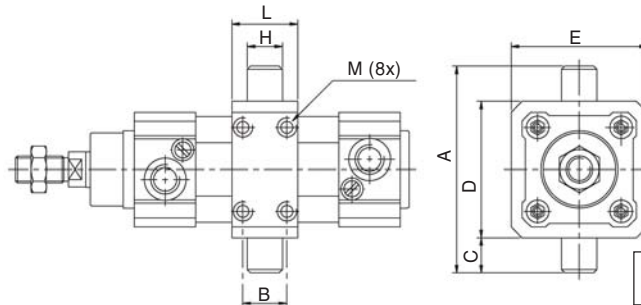

ø mm	A	B	C	D	E	ø H	L	M
32	74	18	12	50	71	12	30	M5
40	95	18	16	63	75	16	30	M5
50	105	23	16	73	95	16	40	M5
63	130	23	20	90	106	20	40	M6
80	148	28	20	108	133	20	50	M6
100	181	28	25	131	155	25	50	M8

Zur separaten Bestellung  
To be ordered separately

Zuganker Tie rod	Profilrohr Profile tube
D0103FA0017	D0103FA0009
D0104FA0017	D0104FA0009
D0105FA0017	D0105FA0009
D0106FA0017	D0106FA0009
D0108FA0017	D0108FA0009
D0110FA0017	D0110FA0009

**Lagerbock für Schwenklager I & R**

Horizontal rear  
hinge for  
trunnion I & R

**L**

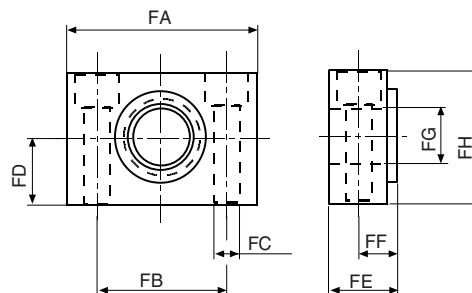

ø mm	FA	FB	FC	FD	FE	FF	FG	FH
32	46	32±0.2	6,6	15±0.1	18	10,5	12	30
40	55	36±0.2	9	18±0.1	21	12	16	36
50	55	36±0.2	9	18±0.1	21	12	16	36
63	65	42±0.2	11	20±0.1	23	13	20	40
80	65	42±0.2	11	20±0.1	23	13	20	40
100	75	50±0.2	14	25±0.1	28,5	16	25	50
125	75	50±0.2	14	25±0.1	28,5	16	25	50
160	92	60±0.3	18	30±0.2	40	22,5	32	60
200	92	60±0.3	18	30±0.2	40	22,5	32	60
250	140	90±0.3	22	35±0.2	56	31	40	70
320	150	100±0.3	26	40±0.2	67	37	50	80

Zur separaten Bestellung  
To be ordered separately

D0103C0011
D0104C0011
D0105C0011
D0106C0011
D0108C0011
D0110C0011
D0112C0011
D0116C0011
D0120C0011
D0125C0011
D0132C0011

## Einbauvarianten • Mounting options

Fußwinkel  
Angle foot

**B**

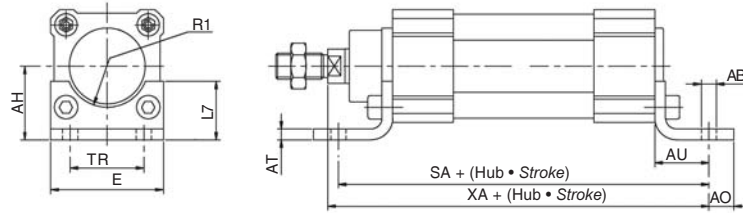

ø mm	ø AB	AH	AO	AT	AU	E	L7	R1	SA	TR	XA
32	7	32	11	5	24	45	26	15,5	142	32	144
40	9	36	15	5	28	52	27	18	161	36	163
50	9	45	15	6	32	65	35	20,5	170	45	175
63	9	50	15	6	32	75	35	23	185	50	190
80	12	63	20	7	41	95	46	23	210	63	215
100	14	71	25	7	41	115	48	28	220	75	230
125	16	90	15	8	45	140	80	31	250	90	270
160	18	115	20	10	60	180	100	33	300	115	320
200	22	135	30	10	70	220	120	38	320	135	375
250	28	165	-	20	75	275	-	45	350	165	380
320	35	200	-	23	85	345	-	55	390	200	425

Zur separaten Bestellung To be ordered separately	
D0103FA0001	
D0104FA0001	
D0105FA0001	
D0106FA0001	
D0108FA0001	
D0110FA0001	
D0112FA0001	
D0116FA0001	
D0120FA0001	
D0125C0001	
D0132C0001	

## Sensorhalterungen • Sensor mounts

Halterung für Reedschalter für  
Pneumatikzylinder ISO 6431 mit  
Profilrohr.

Reed effect magnetic sensor  
mount for ISO 6431 pneumatic  
cylinder with profiled barrel.

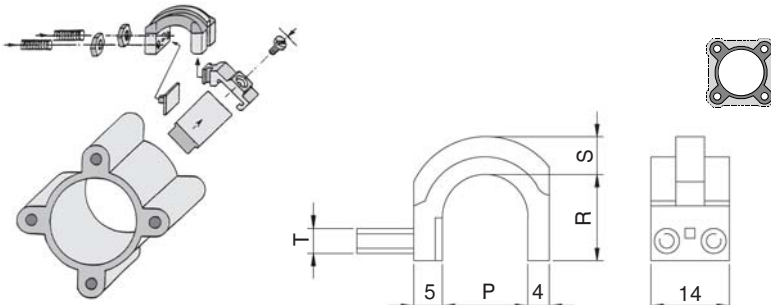

Code	ø mm	P	R	S	T
D0103FA0027	32	12,2	12	6	M4x10
D0104FA0027	40	12,2	12	6	M4x10
D0105FA0027	50	15,5	15,5	7	M4x10
D0106FA0027	63	15,5	15,5	7	M4x10
D0108FA0027	80	15,5	15,5	7	M4x10
D0110FA0027	100	20	19,5	7	M4x20
D0112FA0027	125	20	19,5	7	M4x20
D0114FA0027	160	26	23	7	M4x20
D0116FA0027	200	26	23	7	M4x20

Halterung für Reedschalter für  
alle Pneumatikzylinder ISO 6431  
mit 4 Zugstangen.

Reed effect magnetic sensor  
mount for ISO 6431 pneumatic  
cylinders with 4 tie-rods.

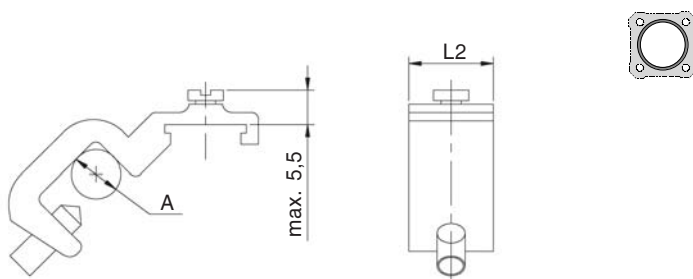

Code	ø mm	A min.	A max.
D0103FA0031	32	4	9
D0103FA0031	40	4	9
D0103FA0031	50	4	9
D0103FA0031	63	4	9
D0108FA0031	80	9	15
D0108FA0031	100	9	15
D0108FA0031	125	9	15
D0116FA0031	160	15	20
D0116FA0031	200	15	20
D0116FA0031	250	15	20
D0132FA0031	320	20	30

## Magnetsensoren • Magnetic sensors

Magnetsensor mit Reedkontakt, elektrischer Anschluß mit Winkelstecker, Leitungslänge 2 m, LED rot.

Reed effect magnetic sensor with 2 m cable and 90° connector, red LED.



Bestellnummer /  
Model Number

**D0100FA0030**

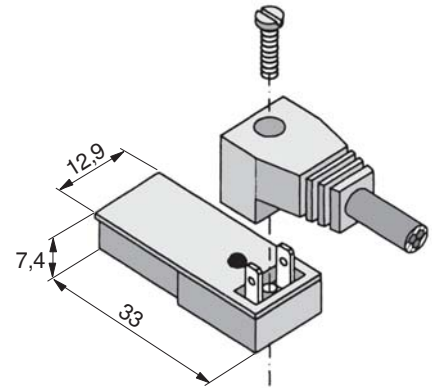

Magnetsensor mit Reedkontakt, Anschlußleitung 2 m eingegossen, LED rot.

Reed effect magnetic sensor with integral 2 m cable and red LED.



Bestellnummer /  
Model Number

**D0100FA0029**

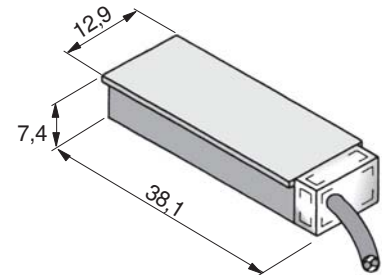

in 10 - 30 V / DC Induktiv PNP = D0100FA0028

### Technische Eigenschaften • Technical characteristics

Kontakt		Contact
Nennspannung	3-250 VDC 3-250 VAC	Nominal voltage
Schaltstrom	1000 mA	Switching current
Max. Leistung	50 W / 50 VA	Max. power
Lebensdauer (Schaltspiele)	10 x 10 <sup>6</sup>	Electrical life (cycles)
Ansprechzeit	2 ms	Response time
Abfallzeit	0,1 ms	Deactivation time
Betriebstemperatur	- 30° C – +80° C	Operating temperature
Erschütterungswiderstand	1000 Hz	Resistance to vibrations
Oberflächenmaterial	PA + 30% GF	Coating material
Schutzart	IP 65	Enclosure rating

#### HINWEIS:

- Der Einsatz von Sensoren limitiert die Arbeitstemperatur der Zylinder.
- Die Intensität des Magnetfeldes nimmt bei Ansteigen der Betriebstemperatur pro 10° C um jeweils 2% ab.

#### NOTE:

- Use of sensors reduces the cylinder's operating temperature.
- The magnetic field intensity decreases by 2% for every 10° C rise in the operating temperature.

# Zylinder mit Feststelleinheit • Cylinder with piston rod lock

Diese Zylinder verfügen über eine Feststelleinheit mit mechanischer Blockierung. Dadurch kann die Kolbenstange in beliebiger Position des Hubes festgehalten werden. Die Kolbenstange wird durch Ineinandergreifen von Klemmelementen des Systems blockiert. Die Haltekraft ist höher als die Schubkraft des Zylinders bei Betrieb mit 6 bar - dieser Druck ist der empfohlene Betriebsdruck. Die Feststelleinheit wird standardmäßig als "drucklos blockiert" N.G. (normal geschlossen) geliefert, Klemmkraft durch eine interne Feder, Lösung durch Druckaufschlag. Für besondere Anwendungen ist die Feststelleinheit jedoch auch "drucklos entriegelt" N.O. (normal offen) erhältlich. Für die Verriegelung ist ein pneumatisches Signal notwendig (s. Hinweis Bestelldaten). Obwohl dieses Element, im Falle von Druckausfall den Zylinder anhalten kann, handelt es sich bei dieser Feststelleinheit nicht um ein "Sicherheitssystem".

These cylinders are equipped with a mechanical piston lock which can lock the rod at any point of its stroke. The piston is locked by mechanical interference between the lock brake shoes and the rod. The locking force is greater than the one that the cylinder can develop when supplied with pressures up to 6 bar, which is also the maximum recommended cylinder operating pressure. The system is supplied as standard in "normally closed" N.C. version; the locking force is supplied by an internal spring, while unlocking is air operated. For special applications a "normally open" N.O. version is also available, in which locking is air operated (see notes in ORDERING section). Although this system, in its standard version, locks the cylinder in case of air pressure failure, it cannot be considered a "safety device".

## TECHNISCHE EIGENSCHAFTEN

1. Die Feststelleinheit kann sowohl für statische als auch für dynamische Klemmung eingesetzt werden.
2. Geringer Verschleiß und hohe Lebensdauer durch Sonderlegierung der Klemmbacken.
3. Die Feststelleinheit kann für Kolbenstangen aus C40 hartverchromt oder für Kolbenstangen aus rostfreiem Stahl verwendet werden.
4. Minimaler Verschleiß der Kolbenstangen durch erweiterte Berührungsflächen.
5. Das eingeschraubte Bodenstück ermöglicht schnellen und leichten Austausch der Klemmbacken. Kolben und Deckel müssen dabei nicht entnommen werden.
6. Die getrennte Bauweise von Adapter und Klemmpatrone ermöglicht dem System den Einsatz aller Kolbenstangen von  $\varnothing$  4 bis 32 mm.

## TECHNICAL CHARACTERISTICS

1. The piston lock provides both static and dynamic braking.
2. Special alloy shoes guarantee low wear and long service.
3. The piston lock unit can be used with C40 hard chrome-plated or stainless steel pistons.
4. Large contact area ensures minimal wear.
5. The rear screw-on end plate enables easy shoe replacement without the need for end-caps and piston disassembly.
6. Modular construction of the mount and lock brake shoes allows use of the system with all rod diameters from 4 to 32 mm.

### Klemmkraft Locking forces

$\varnothing$ mm	Kraft Force (Newton)
10	60
12	120
16	180
20	250
25	350
32	600
40	1000
50	1500
63	2200
80	3000
100	5000
125	7000

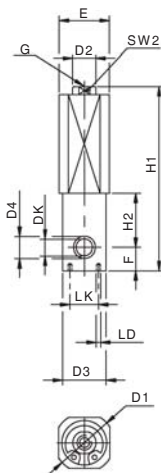

### Magnetisch • Magnetic Klemmpatrone • Brake cartridge

Code		Code		$\varnothing$ mm	DK $\varnothing$	D1 $\varnothing$	D2 $\varnothing$	D3 $\varnothing$	D4 $\varnothing$	E	F	G	H1	H2	SW2	LD $\varnothing$	LK $\varnothing$
N.G./N.C.	N.O.	N.G./N.C.	N.O.														
BM010	AM010	B010	A010	10	4	16	8,5	12	6	14,5	7,25	M5	56	7,5	8	1,1	8,0
BM012	AM012	B012	A012	12	6	20	8,5	16	8	18,5	9,50	M5	64	10	8	1,4	10,5
BM016	AM016	B016	A016	16	6	20	8,5	16	8	18,5	9,50	M5	64	10	8	1,4	10,5
BM020	AM020	B020	A020	20	8	22	9	20	12	20,5	11,50	M5	71	19	8	1,4	13,0
BM025	AM025	B025	A025	25	10	22	9	20	12	20,5	11,50	M5	71	19	8	1,4	13,0
BM032	AM032	B032	A032	32	12	27,5	10	20	14	22,7	17	M5	88	25	8	1,6	14,0
BM040	AM040	B040	A040	40	16	31,5	10	24	18	27,7	19,50	M5	92,5	29	8	2,1	17,5
BM050	AM050	B050	A050	50	20	36	15	30	22	32,7	22,50	G 1/8	115	35	13	2,1	17,5
BM063	AM063	B063	A063	63	20	44	15	38	22	41	25	G 1/8	131,5	42,5	13	2,1	28,0
BM080	AM080	B080	A080	80	25	53	19	40	27	49,7	30	G 1/8	159	52,5	17	2,1	28,0
BM100	AM100	B100	A100	100	25	58	19	48	27	54,7	30	G 1/8	172	65	17	2,1	35,0
BM125	AM125	B125	A125	125	32	65,5	19	65	34	64,9	34	G 1/8	186,5	75	17	3,1	35,0

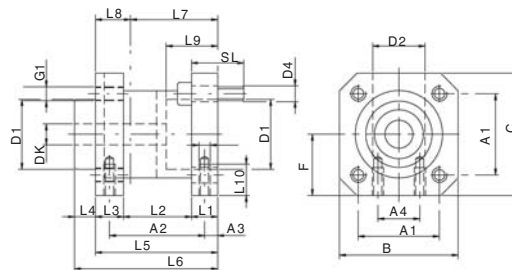



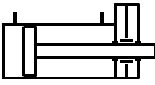

### Adapter • Adaptor

Code	$\varnothing$ mm	DK $\varnothing$	A1	A2	A3	A4	B	C	D1 $\varnothing$	D2 $\varnothing$	D4 $\varnothing$	F	G1	G2	L1	L2	L3	L4	L5	L6	L7	L8	L9	L10	SL
BF032	32	12	32,5	40	4,2	16	48	50	30	20	6,6	25	M 6	M 5	8	28	12	10	48	58	32	16	20,5	8	20
BF040	40	16	38	46	4,5	21	56	58	35	24	6,6	29	M 6	M 5	10	33	12	10	55	65	35,5	19,5	22,5	10	20
BF050	50	20	46,5	54	11,5	24	68	70	40	30	8,5	35	M 8	M 6	15	39	16	12	70	82	49	21	29,5	12	30
BF063	63	20	56,5	60	9,5	32	82	85	45	38	8,5	42,5	M 8	M 8	15	47	16	12	78	90	49	29	29,5	16	30
BF080	80	25	72	70	10	44	100	105	45	40	11	52,5	M 10	M 8	16	58	17,5	18,5	91,5	110	62	29,5	35,5	16	35
BF100	100	25	89	70	10	60	120	130	55	48	11	65	M 10	M 8	16	58	18	23	92	115	65	27	38,5	16	35
BF125	125	32	110	95	11	75	140	150	60	65	13	75	M 12	M 10	25	70	27	32	122	154	85	37	45,5	20	20

# Zylinder mit Feststelleinheit • Cylinder with piston rod lock

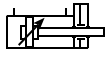
Zylinder mit Einzelstange		Single rod cylinder
Stahl C40 mit Chromauftrag	<b>O</b>	C40 steel, chrome-plated
AISI 303 mit Chromauftrag	<b>C</b>	AISI 303, chrome-plated
Inox AISI 303	<b>X</b>	Stainless steel, AISI 303

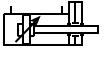

<b>Aluminiumprofilrohr ohne Zugstangen</b> Aluminium profile without tie-rods 		STANDARD	HEAVY	VIGOR	ACTION		STANDARD	HEAVY	VIGOR	ACTION
		<b>N</b>	<b>H</b>	<b>V</b>	<b>A</b>		<b>N</b>	<b>H</b>	<b>V</b>	<b>A</b>
<b>Aluminiumprofilrohr mit 4 Zugstangen</b> Aluminium profile with 4 tie-rods 		STANDARD	HEAVY	VIGOR	ACTION		STANDARD	HEAVY	VIGOR	ACTION
		<b>N</b>	<b>H</b>	<b>V</b>	<b>A</b>		<b>N</b>	<b>H</b>	<b>V</b>	<b>A</b>

## Zusätzliche Kolbenstange Extra piston rod

ø mm	(+ mm)
32	+ 48,0
40	+ 55,0
50	+ 70,0
63	+ 78,0
80	+ 91,5
100	+ 92,0
125	+ 122,0

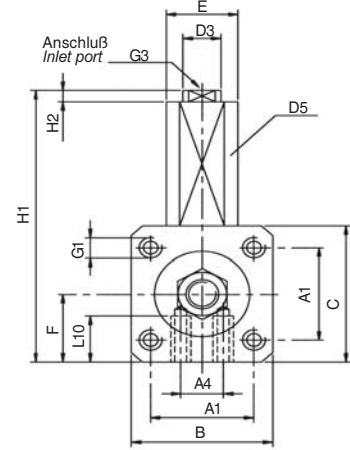
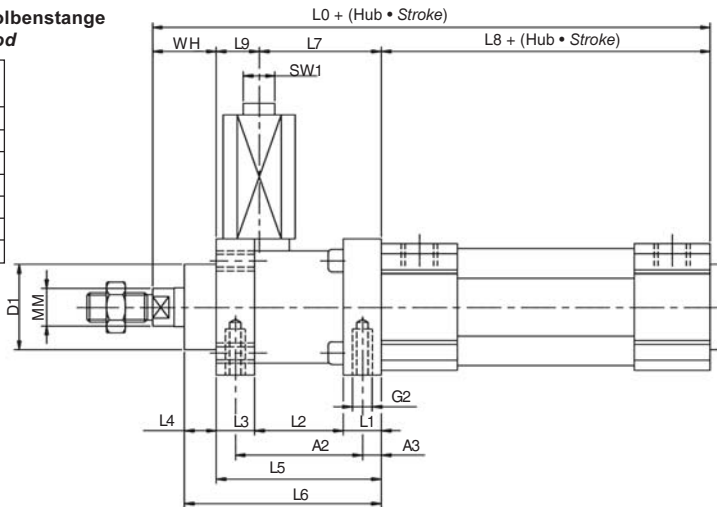

Übrige Abmessungen siehe Seiten 7, 8 und 22.  
For all other dimensions refer to pages 7, 8 and 22.

Code	ø mm	L0	L1	L2	L3	L4	L5	L6	L7	L8	L9	L10	A1	A2	A3	A4	B	C	D1 ø	D3 ø	D5 ø	E □	F	G1	G2	G3	H1	H2	MM ø	SW1	WH	Gewicht, Weight	
																																0mm g	1mm g/mm
B0103F	32	168	8	28	12	10	48	58	32	94	16	8	32,5	40	4,2	16	48	50	30	10	27,5	22,7	25	M6	M5	M5	96	4	12	8	26	780	2,26
B0104F	40	190	10	33	12	10	55	65	35,5	105	19,5	10	38	46	4,5	21	56	58	35	10	31,5	27,7	29	M6	M5	M5	102	4	16	8	30	1160	3,20
B0105F	50	213	15	39	16	12	70	82	49	106	21	12	46,5	54	11,5	24	68	70	40	15	36	32,7	35	M8	M6	G 1/8	127	4	20	13	37	2000	4,66
B0106F	63	236	15	47	16	12	78	90	49	121	29	16	56,5	60	9,5	32	82	85	45	15	44	41	42,5	M8	M6	G 1/8	151,5	4	20	13	37	3000	5,10
B0108F	80	265,5	16	58	17,5	18,5	91,5	110	62	128	29,5	16	72	70	10	44	100	105	45	19	53	49,7	52,5	M10	M8	G 1/8	181,5	4	25	17	46	5370	7,45
B0110F	100	281	16	58	18	23	92	115	65	138	27	16	89	70	10	60	120	130	55	19	58	54,7	65	M10	M8	G 1/8	207	4	25	17	51	8300	8,70
B0112FM	125	347	25	70	27	32	122	154	85	160	37	20	110	95	11	75	140	150	60	19	67,5	64,9	75	M12	M10	G 1/8	227	4	32	17	32	12400	13,40

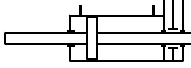

# Zylinder mit Feststelleinheit • Cylinder with piston rod lock

Mit durchgehender Kolbenstange		Double rod cylinder
Stahl C40 mit Chromauftrag	<b>P</b>	C40 steel, chrome-plated
AISI 303 mit Chromauftrag	<b>R</b>	AISI 303, chrome-plated
Inox AISI 303	<b>W</b>	Stainless steel, AISI 303

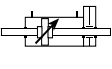
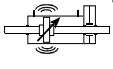
Aluminiumprofilrohr ohne Zugstangen Aluminium profile without tie-rods								
	STANDARD	HEAVY	VIGOR	ACTION	STANDARD	HEAVY	VIGOR	ACTION
	<b>N</b>	<b>H</b>	<b>V</b>	<b>A</b>	<b>N</b>	<b>H</b>	<b>V</b>	<b>A</b>

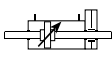
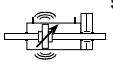
Aluminiumprofilrohr mit 4 Zugstangen Aluminium profile with 4 tie-rods								
	STANDARD	HEAVY	VIGOR	ACTION	STANDARD	HEAVY	VIGOR	ACTION
	<b>N</b>	<b>H</b>	<b>V</b>	<b>A</b>	<b>N</b>	<b>H</b>	<b>V</b>	<b>A</b>

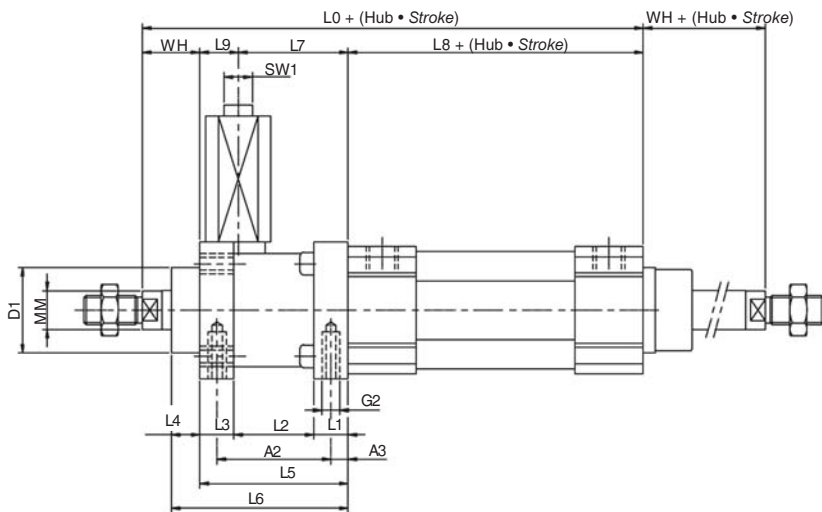









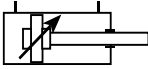
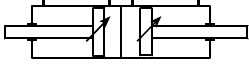
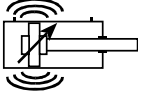
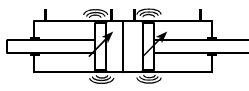

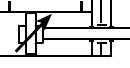

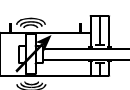

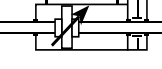

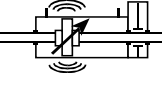
Übrige Abmessungen siehe Seiten 7, 8, 9 und 22.  
For all other dimensions refer to pages 7, 8, 9 and 22.

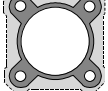
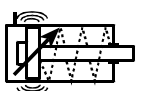
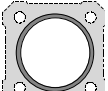
Code	ø mm	L0	L1	L2	L3	L4	L5	L6	L7	L8	L9	L10	A1	A2	A3	A4	B	C	D1 ø	D3 ø	D5 ø	E □	F	G1	G2	G3	H1	H2	MM ø	SW1	WH	Gewicht, Weight	
																																0mm g	1mm g/mm
B0103F	32	168	8	28	12	10	48	58	32	94	16	8	32,5	40	4,2	16	48	50	30	10	27,5	22,7	25	M6	M5	M5	96	4	12	8	26	780	2,26
B0104F	40	190	10	33	12	10	55	65	35,5	105	19,5	10	38	46	4,5	21	56	58	35	10	31,5	27,7	29	M6	M5	M5	102	4	16	8	30	1160	3,20
B0105F	50	213	15	39	16	12	70	82	49	106	21	12	46,5	54	11,5	24	68	70	40	15	36	32,7	35	M8	M6	G1/8	127	4	20	13	37	2000	4,66
B0106F	63	236	15	47	16	12	78	90	49	121	29	16	56,5	60	9,5	32	82	85	45	15	44	41	42,5	M8	M6	G1/8	151,5	4	20	13	37	3000	5,10
B0108F	80	265,5	16	58	17,5	18,5	91,5	110	62	128	29,5	16	72	70	10	44	100	105	45	19	53	49,7	52,5	M10	M8	G1/8	181,5	4	25	17	46	5370	7,45
B0110F	100	281	16	58	18	23	92	115	65	138	27	16	89	70	10	60	120	130	55	19	58	54,7	65	M10	M8	G1/8	207	4	25	17	51	8300	8,70
B0112FM	125	347	25	70	27	32	122	154	85	160	37	20	110	95	11	75	140	150	60	19	67,5	64,9	75	M12	M10	G1/8	227	4	32	17	32	12400	13,40

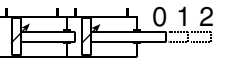

## Legende • Key

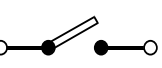
	<b>Doppeltwirkend</b> <i>Double-acting</i>		<b>Gegenüberliegende Kolbenstangen</b> <i>Double piston, back to back</i>
	<b>Doppeltwirkend, magnetisch</b> <i>Double-acting, magnetic</i>		<b>Gegenüberliegende Kolbenstangen, magnetisch</b> <i>Magn. double piston, back to back</i>
	<b>Durchgehende Kolbenstange</b> <i>Double piston-rod</i>		<b>Doppeltwirkend mit Feststelleinheit</b> <i>Double-acting with piston lock</i>
	<b>Durchgehende Kolbenstange, magnetisch</b> <i>Double piston-rod, magnetic</i>		<b>Doppeltwirkend mit Feststelleinheit, magnetisch</b> <i>Double-acting, magnetic, with piston lock</i>
	<b>Tandem</b>		<b>Durchgehende Kolbenstange und Feststelleinheit</b> <i>Double rod with piston lock</i>
	<b>Tandem, magnetisch</b> <i>Tandem, magnetic</i>		<b>Durchgehende Kolbenstange und Feststelleinheit, magnetisch</b> <i>Double rod with piston lock, magnetic</i>
	<b>Einfachwirkend, Feder kopfseitig</b> <i>Single action, normally retracted</i>		<b>Aluminiumprofilrohr ohne Zugstangen</b> <i>Aluminium profile without tie-rods</i>
	<b>Einfachwirkend, Feder kopfseitig, magnetisch</b> <i>Single action, magnetic, normally retracted</i>		<b>Aluminiumprofilrohr mit 4 Zugstangen</b> <i>Aluminium profile with 4 tie-rods</i>
	<b>Einfachwirkend, Feder bodenseitig</b> <i>Single action, normally extended</i>		<b>Betriebsdruck</b> <i>Operating pressure</i>
	<b>Einfachwirkend, Feder bodenseitig, magnetisch</b> <i>Single action, magnetic, normally extended</i>		<b>Temperaturbereich</b> <i>Operating temperature</i>
	<b>Doppelkolben für 3 Stellungen</b> <i>Double piston-rod, 3 positions</i>		<b>Betrieb mit / ohne Luftschiemung</b> <i>Operation with / without lubricated air</i>
	<b>Doppelkolben für 3 Stellungen, magnetisch</b> <i>Double piston-rod, magnetic, 3 positions</i>		<b>Normal offen</b> <i>Normally open</i>

# Wichtige Hinweise

## Montage/Wartung

1. Stellen Sie sicher, daß vor der Aufnahme von Wartungsarbeiten an Pneumatikventilen oder anderen Komponenten die Stromversorgung unterbrochen und das gesamte Pneumatik-System abgeschaltet und entlüftet wird (gem. EN 1037).
2. Alle ROSS-Produkte, einschl. Reparatursätze und Ersatzteile, dürfen nur von speziell geschulten, erfahrenen Fachkräften installiert und/oder gewartet werden. Alle Anlagenteile müssen in regelmäßigen Abständen durch qualifiziertes Personal, das für die Sicherheit am Arbeitsplatz und für den störungsfreien Betrieb der Anlage verantwortlich ist, geprüft und - falls notwendig - gewartet werden.
3. Um Personen- und Materialschäden zu vermeiden, sind die entsprechenden Betriebs- und Wartungsrichtlinien unbedingt gründlich zu lesen und zu befolgen. Technisch überholte oder gewartete Ventile müssen vor der erneuten Inbetriebnahme einem Funktionstest unterzogen werden.
4. Alle ROSS-Produkte dürfen nur gemäß den entsprechenden technischen Daten eingesetzt werden. Für die Reparatur von ROSS-Produkten dürfen nur ROSS-Ersatzteile verwendet werden. Nichtbeachtung dieser Anwendungshinweise kann die Funktion der Produkte beeinträchtigen und zu Unfallgefahr führen.

## Filtern/Schmieren

5. Luftleitungen in Pneumatik-Systemen sind nie völlig frei von festen oder flüssigen Schmutzpartikeln. Zwar wird dadurch die Leistungsfähigkeit der Ventile im allgemeinen nicht beeinträchtigt; doch um zu verhindern, daß Verunreinigungen im nachgeschalteten System Betriebsstörungen verursachen, sollte die Versorgungsluft durch einen Filter gereinigt werden. Für Einsätze unter Standardbedingungen empfehlen wir Filter mit einer Porenweite von 5 Mikron.
6. Alle ROSS-Standardfilter und Ölvernebler mit Polykarbonat-Kunststoffbehältern sind ausschließlich für Druckluftbetrieb ausgelegt. Um möglichen Gefahren vorzubeugen, sollten Sie Kunststoff-Behälter keinesfalls ohne Metallschutz verwenden; dies gilt insbesondere, wenn die Filterreinheit außergewöhnlichen Anforderungen ausgesetzt wird. Stellen Sie sicher, daß bestimmte gefährliche Flüssigkeiten oder Gase wie zum Beispiel Alkohol oder verflüssigte Petrolgase nicht in das System gelangen; dies könnte zu Beschädigungen am Behälter führen und Brandrisiken, gefährliche Leckagen oder sonstige bedrohliche Situationen heraufbeschwören.

Wechseln Sie auch geringfügig beschädigte Behälter aus Sicherheitsgründen sofort aus. Bei Verschmutzung den Behälter entweder austauschen oder mit einem sauberen, trockenen Tuch reinigen.

7. Benutzen Sie nur Schmiermittel, die Dichtungen, Ventilteller und andere Komponenten im System nicht angreifen. Generell kann jedes leichte Mineralöl mit Antioxydationsmitteln, einem Anilinpunkt zwischen 82°C und 104°C und einer Viskosität VG 32 nach ISO 3448 (32mm<sup>2</sup>/s bei 40°C) verwendet werden. Öle mit phosphathaltigen Additiven sind ungeeignet, da sie Polyurethan-Ventilteile angreifen. Wir empfehlen, in Ihrem Pneumatiksystem nur speziell für Öler in Druckluftanlagen geeignete Öle zu verwenden.

## Vermeiden Sie Leitungsverengungen

8. Die Eintrittsleitung darf nicht durch Drosselstellen wie z.B. scharfe Knicke verengt werden, da diese zu einem Druckabfall unter den empfohlenen Mindestdruck und einer unregelmäßigen Arbeitsweise des Ventils führen könnten.

9. Eine Zusammenführung der Ventil-Entlüftungspforte kann die Ventilfunktion beeinträchtigen. Schalldämpfer dürfen sich nicht durch Verschmutzung zusetzen und müssen eine größere Durchflußkapazität als die Entlüftungspforten der Ventile aufweisen. Ein verunreinigter Schalldämpfer kann die Durchflußgeschwindigkeit der Luft stark mindern und einen Rückstau verursachen. *ROSS übernimmt keine Gewähr oder Verantwortung für Funktionsstörungen oder Personenschäden, die durch Verwendung eines ungeeigneten Schalldämpfers oder durch dessen unsachgemäße Wartung entstehen.*

## Zwillingsmagnetventile

10. An mechanischen Pressen und anderen gefahrenträchtigen Maschinen, die mit pneumatisch betätigten Kupplungen und Bremsen ausgerüstet sind, sollten Zwillingsmagnetventile mit Monitor eingesetzt werden. Zwillingsmagnetventile ohne Selbstüberwachung sollten nur eingesetzt werden, wenn dies die entsprechenden Vorschriften gestatten und wenn das Ventil in Verbindung mit einem Kontrollsystem eingesetzt wird, das die Überwachung von Ventil und Maschine gewährleistet.

## Sicherheitsabsperrfunktion

11. L-O-X® und L-O-X®/EEZ-ON®-Ventile von ROSS dienen als Sicherheitsabsperrentile im Sinne der Vorschrift EN 1037. Sie dürfen nicht als NOT-AUS-Ventile eingesetzt werden.

## Gewährleistung

ROSS gewährleistet für die Dauer eines Jahres vom Datum des Gefahrübergangs, daß die von ihr hergestellten Erzeugnisse keine Mängel wegen fehlerhafter Bauart, Ausführung oder schlechter Baustoffe aufweisen. Unter Ausschluß jeglicher weiterer Haftung beschränkt sich die von ROSS gemäß dem vorher Gesagten übernommene Gewährleistung ausschließlich darauf, daß Teile, die ROSS frachtfrei zugestellt und von ihr nach Überprüfung für mangelhaft befunden wurden, nach Wahl von ROSS entweder unentgeltlich ausgebessert oder ersetzt werden oder daß statt dessen dem Käufer eine Gutschrift für den Kaufpreis gewährt wird. Diese Gewährleistung entfällt, wenn das Erzeugnis einer ungeeigneten oder unsachgemäßen Verwendung unterworfen, wenn es ungenügend oder falsch gewartet oder wenn es seitens des Käufers durch Eingriff abgewandelt wurde. Über diese Gewährleistung hinaus übernimmt ROSS keine Haftung irgendwelcher Art in bezug auf Verwendbarkeit oder Eignung ihrer Erzeugnisse für einen bestimmten Verwendungszweck. ROSS übernimmt keine Gewähr dafür, daß ihre Erzeugnisse irgendwelchen gesetzlichen Unfallverhütungs- und/oder Gesundheitsschutzvorschriften entsprechen. ROSS haftet weder für unmittelbare noch für mittelbare Schäden jedweder Art; insbesondere Unfälle des Käufers, seiner Mitarbeiter oder Dritter. Jegliche weitergehenden Ansprüche des Käufers, gleich auf welchem Rechtsgrunde, die außerhalb dieser Gewährleistung erhoben werden oder auf der sachgemäßen oder unsachgemäßen Verwendung der ROSS-Erzeugnisse beruhen, sind, soweit gesetzlich zulässig, ausdrücklich ausgeschlossen. Auch Dritte, insbesondere Vertreter von ROSS, sind nicht ermächtigt, dem vorher Gesagten zuwider Gewährleistungen oder Haftungen für ROSS zu übernehmen.

# Cautions

## PRE-INSTALLATION or SERVICE

1. Before servicing a valve or other pneumatic component, be sure that all sources of energy are turned off, the entire pneumatic system is shut off and exhausted, and all power sources are locked out (ref.: EN 1037).

2. All ROSS products, including service kits and parts, should be installed and/or serviced only by persons having training and experience with pneumatic equipment. Because any installation can be tampered with or need servicing after installation, persons responsible for the safety of others or the care of equipment must check every installation on a regular basis and perform all necessary maintenance.

3. All applicable instructions should be read and complied with before using any fluid power system in order to prevent harm to persons and/or equipment. In addition, overhauled or serviced valves must be functionally tested prior to installation and use.

4. Each ROSS product should be used within its specification limits. In addition, use only ROSS parts to repair ROSS products. Failure to follow these directions can adversely affect the performance of the product or result in the potential for human injury.

## FILTRATION and LUBRICATION

5. Dirt, scale, moisture, etc. are present in virtually every air system. Although some valves are more tolerant of these contaminants than others, best performance will be realized if a filter is installed to clean the air supply, thus preventing contaminants from interfering with the proper performance of the equipment. ROSS recommends a filter with a 5-micron rating for normal applications.

6. All standard ROSS filters and lubricators with polycarbonate plastic bowls are designed for compressed air applications only. Do not fail to use the metal bowl guard, where provided, to minimize danger from high pressure fragmentation in the event of bowl failure. Do not expose these products to certain fluids, such as alcohol or liquified petroleum gas, as they can cause bowls to rupture, creating a combustible condition, hazardous leakage, and the potential for human injury. Immediately replace a crazed, cracked or deteriorated bowl. When the bowl gets dirty, replace it or wipe it with clean dry cloth.

7. Only use lubricants which are compatible with materials used in the valves and other components in the system. Normally, compatible lubricants are petroleum base oils with oxidation inhibitors, and an aniline point between 82°C and 104°C, and viscosity VG 32 according to ISO 3448 (32mm<sup>2</sup>/s at 40°C), or higher. Oils with phosphate type additives, such as zinc dithiophosphate, must be avoided because they can harm polyurethane valve components. The best oils to use in pneumatic systems are those specifically compounded for air line lubricator service.

## AVOID INTAKE/EXHAUST RESTRICTION

8. Do not restrict the air flow in the supply line. To do so could reduce the pressure of the supply air below the minimum requirements for the valve and thereby cause erratic action.

9. Do not restrict a poppet valve's exhaust port as this can adversely affect its operation. Exhaust silencers must be resistant to clogging and have flow capacities at least as great as the exhaust capacities of the valves. Contamination of the silencer can result in reduced flow and increased back pressure. *ROSS expressly disclaims all warranties and responsibility for any unsatisfactory performance or injuries caused by the use of the wrong type, wrong size, or inadequately maintained silencer installed with a ROSS product.*

## DOUBLE VALVES

10. Mechanical power presses and other potentially hazardous machinery using a pneumatically controlled clutch and brake mechanism must use a press control double valve with a monitoring device. A double valve without a self-contained monitoring device should be used only in conjunction with a control system which assures monitoring of the valve. All double valve installations involving hazardous applications should incorporate a monitoring system which inhibits further operation of the valve and machine in the event of a failure within the valve mechanism.

## ENERGY ISOLATION/EMERGENCY STOP

11. Per specifications and regulations, ROSS L-O-X® and L-O-X®/EEZ-ON® products are defined as energy isolation devices, NOT AS EMERGENCY STOP DEVICES.

## Warranty

Products manufactured by ROSS are warranted to be free of defects in material and workmanship for a period of one year from the date of purchase. ROSS' obligation under this warranty is limited to repair or replacement of the product or refund of the purchase price paid solely at the discretion of ROSS and provided such product is returned to ROSS freight prepaid and upon examination by ROSS is found to be defective. This warranty shall be void in the event that product has been subject to misuse, misapplication, improper maintenance, modification or tampering. The warranty expressed above is in lieu of and exclusive of all other warranties and ROSS expressly disclaims all other warranties either expressed or implied with respect to merchantability or fitness for a particular purpose. ROSS makes no warranty with respect to its products meeting the provisions of any governmental occupational safety and/or health laws or regulations. In no event shall ROSS be liable to purchaser, user, their employees or others for incidental or consequential damages which may result from a breach of the warranty described above or the use or misuse of the products. No statement of any representative or employee of ROSS shall extend the liability of ROSS as set forth herein.





**ROSS** EUROPA GmbH  
Robert-Bosch-Straße 2  
D-63225 Langen  
Tel.: 0049-06103-7597-0  
Fax: 0049-06103-74694  
[www.rosseuropa.com](http://www.rosseuropa.com)



**ROSS** UK Ltd.  
Cakemore Road, Rowley Regis,  
Warley, West Midlands, B65 0QW  
Großbritannien  
Tel.: 0044-121 559 4900  
Fax: 0044-121 559 5309  
[www.rossuk.com](http://www.rossuk.com)

**ROSS** CONTROLS®  
P.O. Box 7015,  
Troy, Michigan 48007 U.S.A.  
Tel.: 001-248-764-1800  
Fax: 001-248-764-1850  
[www.rosscontrols.com](http://www.rosscontrols.com)

**ROSS** ASIA K.K.  
1-10-12 Tanashioda, Sagamihara-shi  
Kanagawa 229-1125, Japan  
Telefon: 0081-427-78-7251  
Fax: 0081-427-78-7256  
[www.rossasia.co.jp](http://www.rossasia.co.jp)

**ROSS** SOUTH AMERICA Ltda.  
Rua Olavo Goncalves, 43/47 - Centro  
Sao Bernardo do Campo - Sao Paulo  
Brasilien - CEP 09725-020  
Tel.: 0055-11-4335-2200  
Fax: 0055-11-4335-3888

**ROSS** CONTROLS INDIA Pvt. Ltd.  
L-21, (Plot No.113)  
Ambattur Industrial Estate  
Chennai 600 058  
Tamilnadu, India  
Tel.: 0091-44-2624-9040  
Fax: 0091-44-2625-8730  
[www.rossindia.com](http://www.rossindia.com)

**ROSS** ASIA K.K.-  
CHINA LIAISON OFFICE  
Room 17B, FuHai Building,  
288 Huanghe Road  
Shanghai, China  
Telefon: 0021-6372-2579  
Fax: 0021-6372-2505